

GE Drive System Training

AC Drive Dual IGBT 17KG535 Cabinet

AC Drive Dual IGBT 17KG537 Cabinet

Supplement Invertex 1E Enhancements

Supplement Invertex 2

- Drive System History
- Part Numbers and Serial Number Encoding

WARNING!!

The **AC DRIVE** System
Has *HIGH VOLTAGE*

In the electric cabinet,
Wheel motors,
Retard grid, etc.

If the engine is running.

There may also be
HIGH VOLTAGE if the
Engine has operated recently.

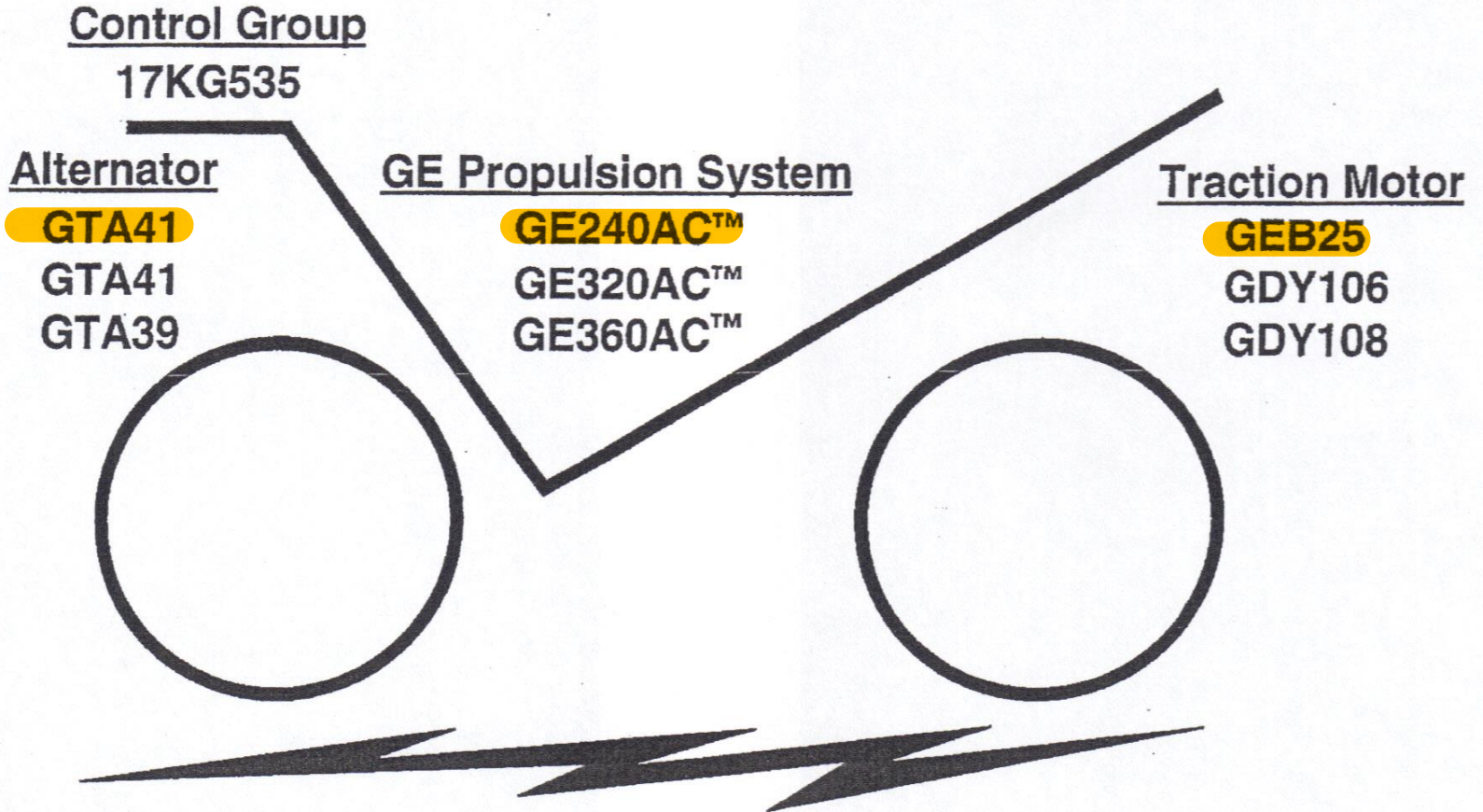

TRAINING MANUAL OFF HIGHWAY VEHICLES

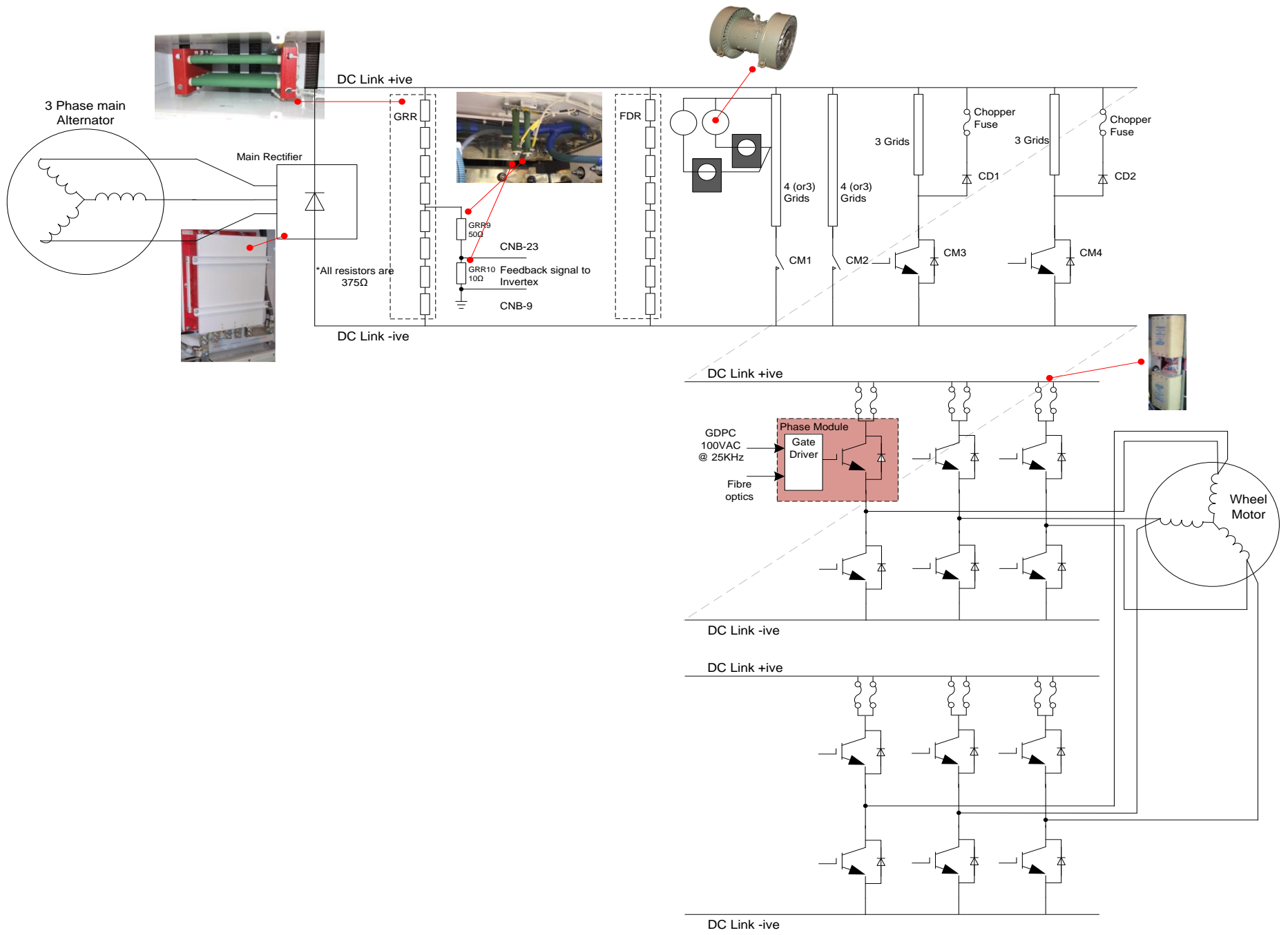

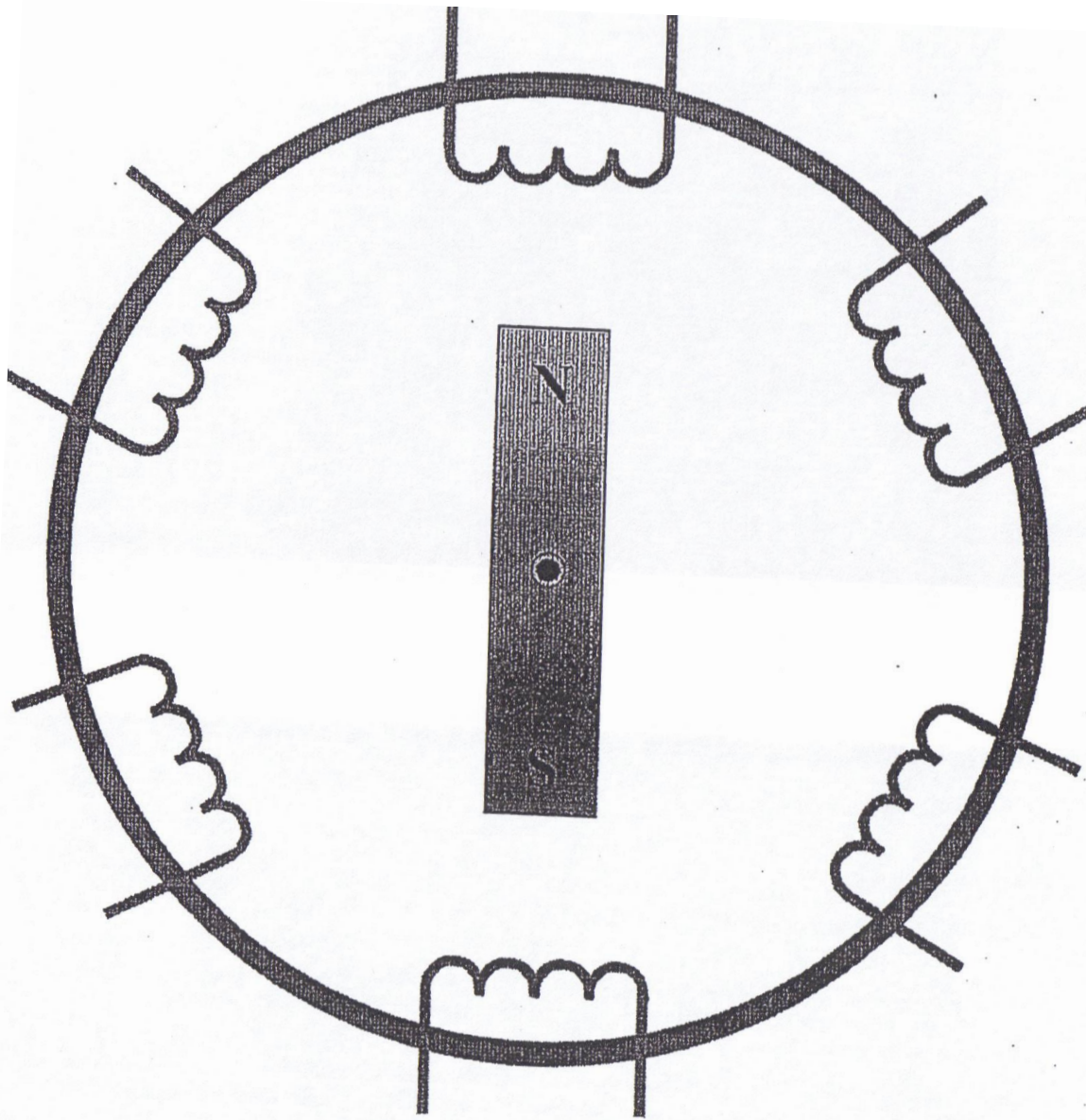

BASIC AC MOTOR OPERATION

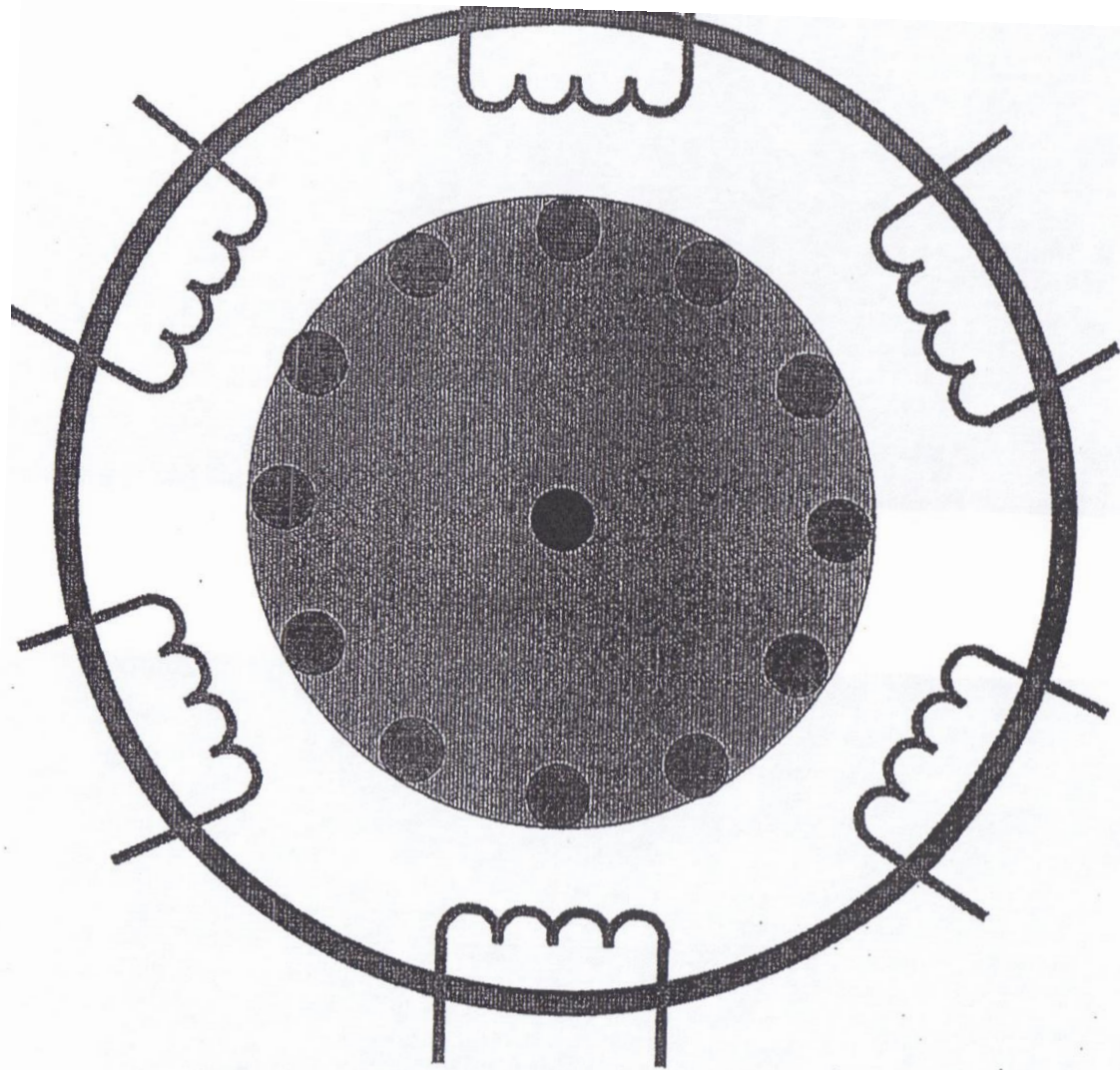

BASIC AC MOTOR OPERATION

Linear Representation of Motoring

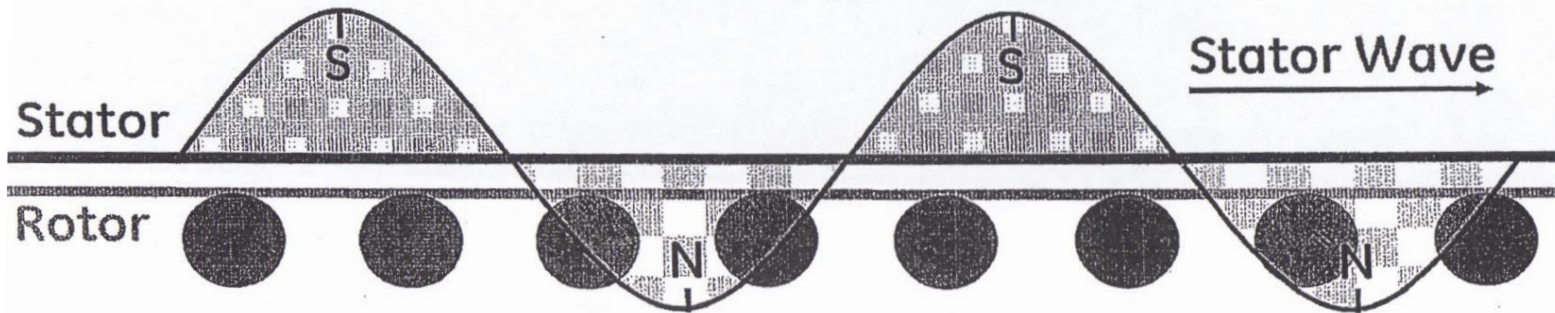

Stator wave cuts rotor bars.

BASIC AC MOTOR OPERATION

Linear Representation of Motoring

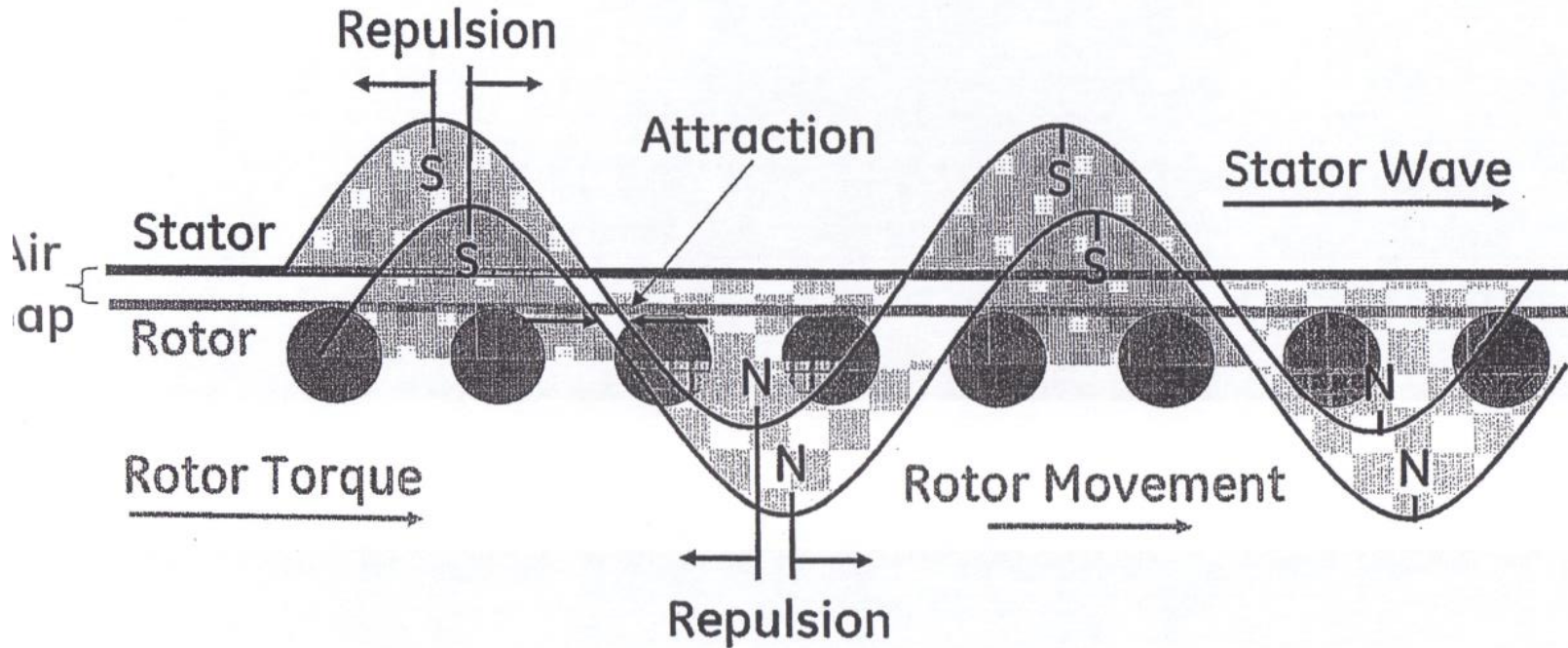

$\text{Rotor Movement} < (\text{Slower than}) \text{ Stator Wave}$ [difference = slip]

Resultant rotor wave creates both attraction and repulsion, torque is produced in the same direction as the stator wave and the rotor turns.

BASIC AC MOTOR OPERATION

Figure 8

Linear Representation of Regenerating

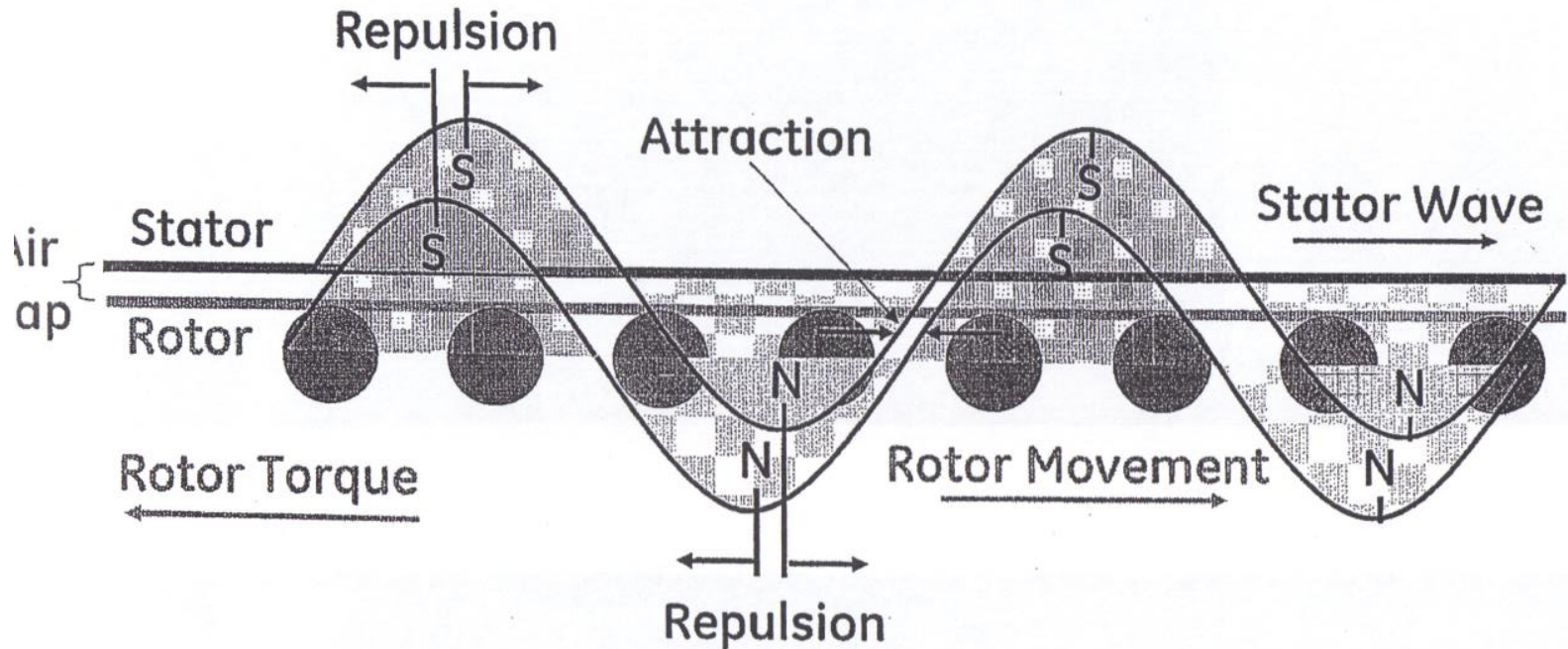

Rotor Movement > (Faster than) Stator Wave [difference = slip]

Resultant rotor wave creates both attraction and repulsion, torque is produced in the opposite direction of the stator wave and the rotor slows.

BASIC AC MOTOR OPERATION

Figure 9

SHOOT THOROUGH HAPPENS WHEN
A+ & A- OR VICE VERSA FIRE AT THE
SAME TIME. DESTROYS THE PHASE
MODUALS

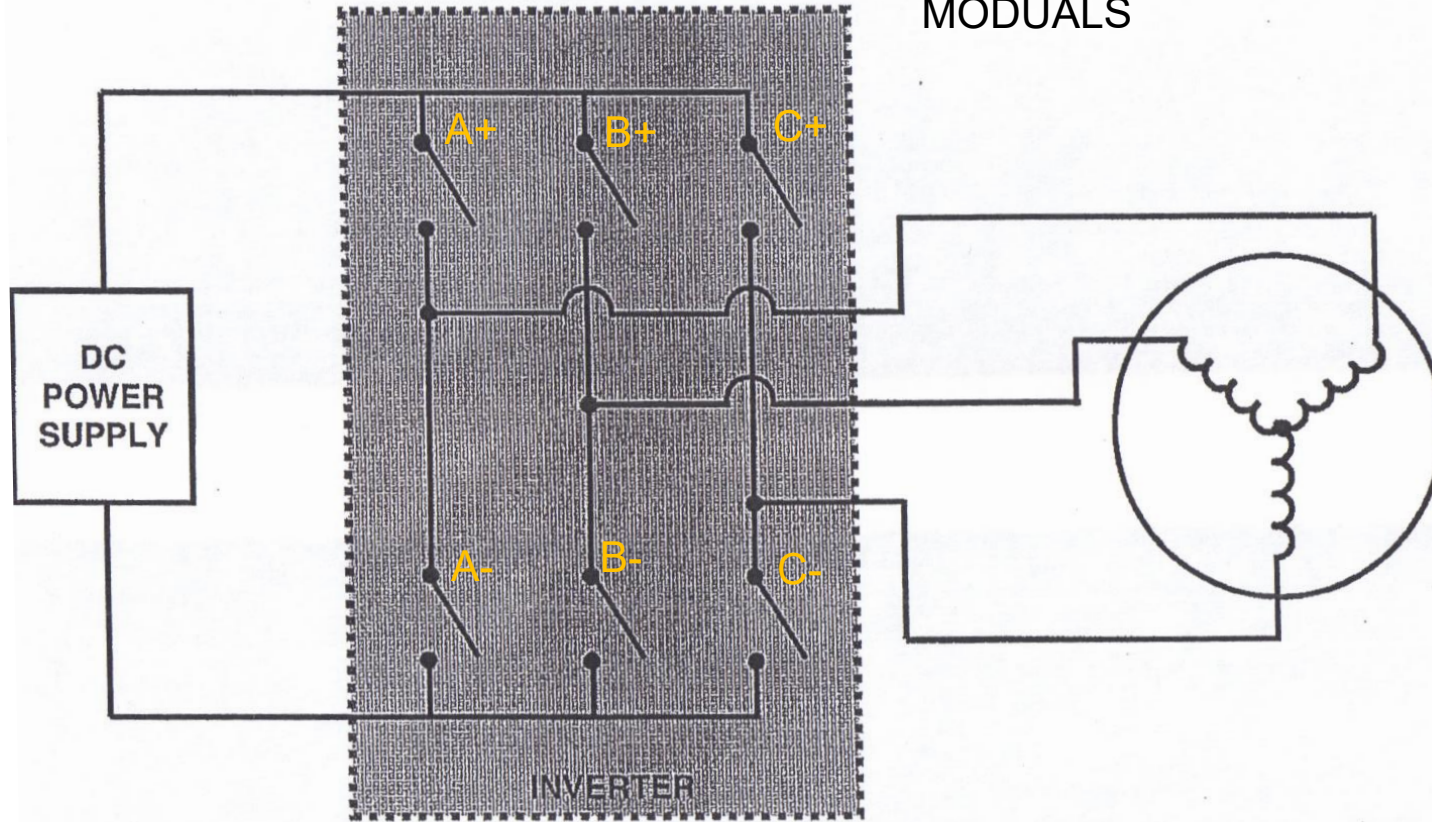

BASIC AC INVERTER

Figure 10

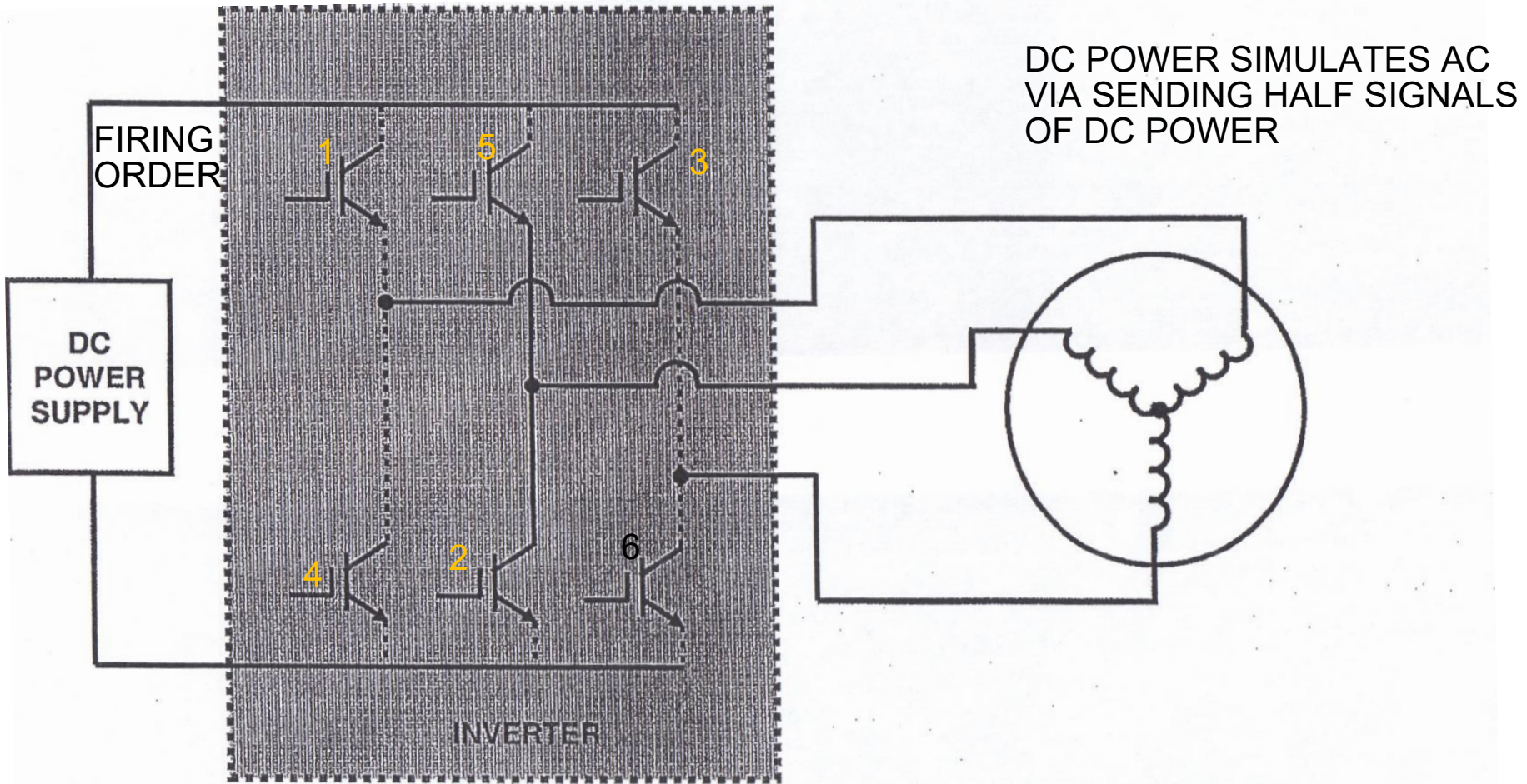

BASIC INVERTER WITH IGBTs

Figure 11

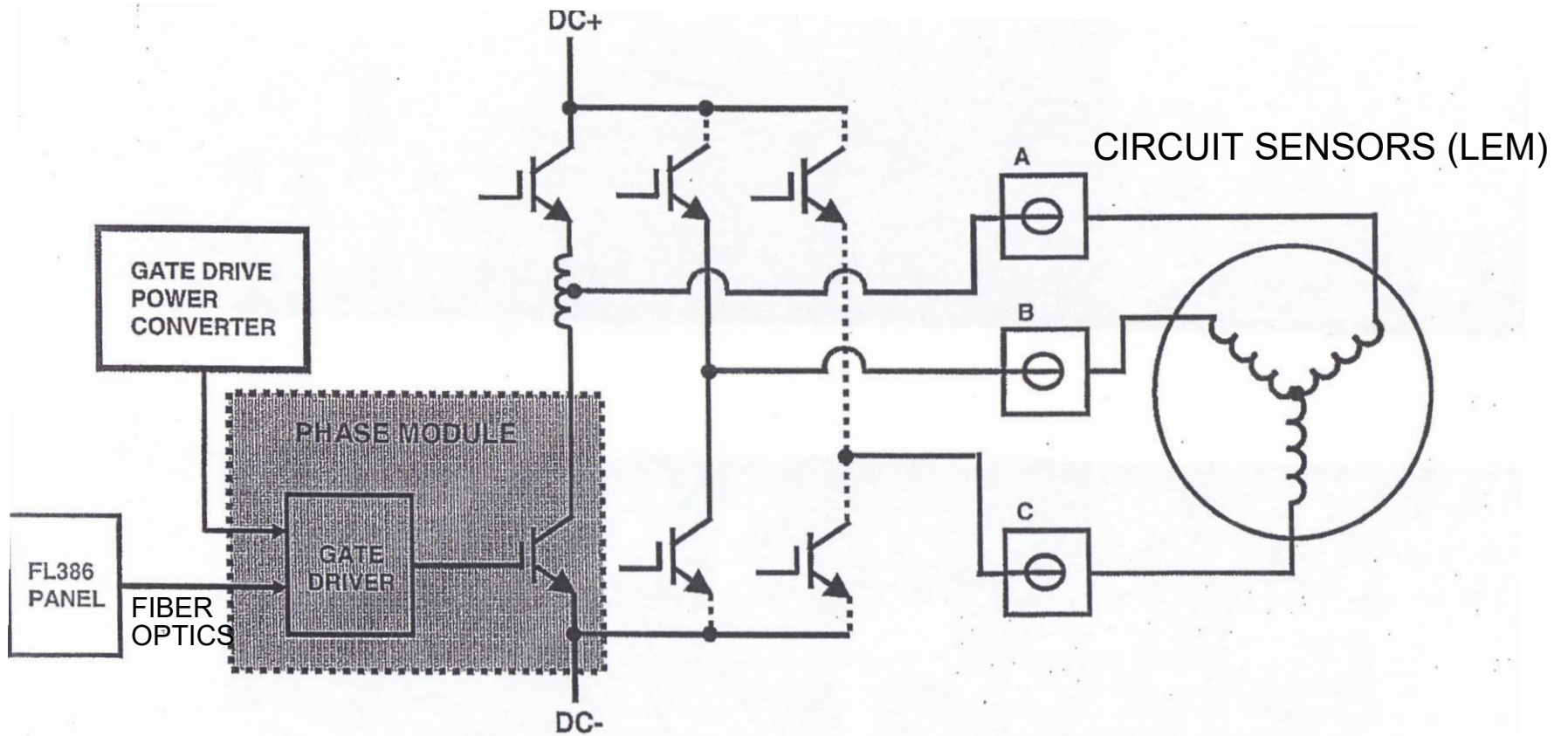

BASIC PHASE MODULE CIRCUIT

Figure 12

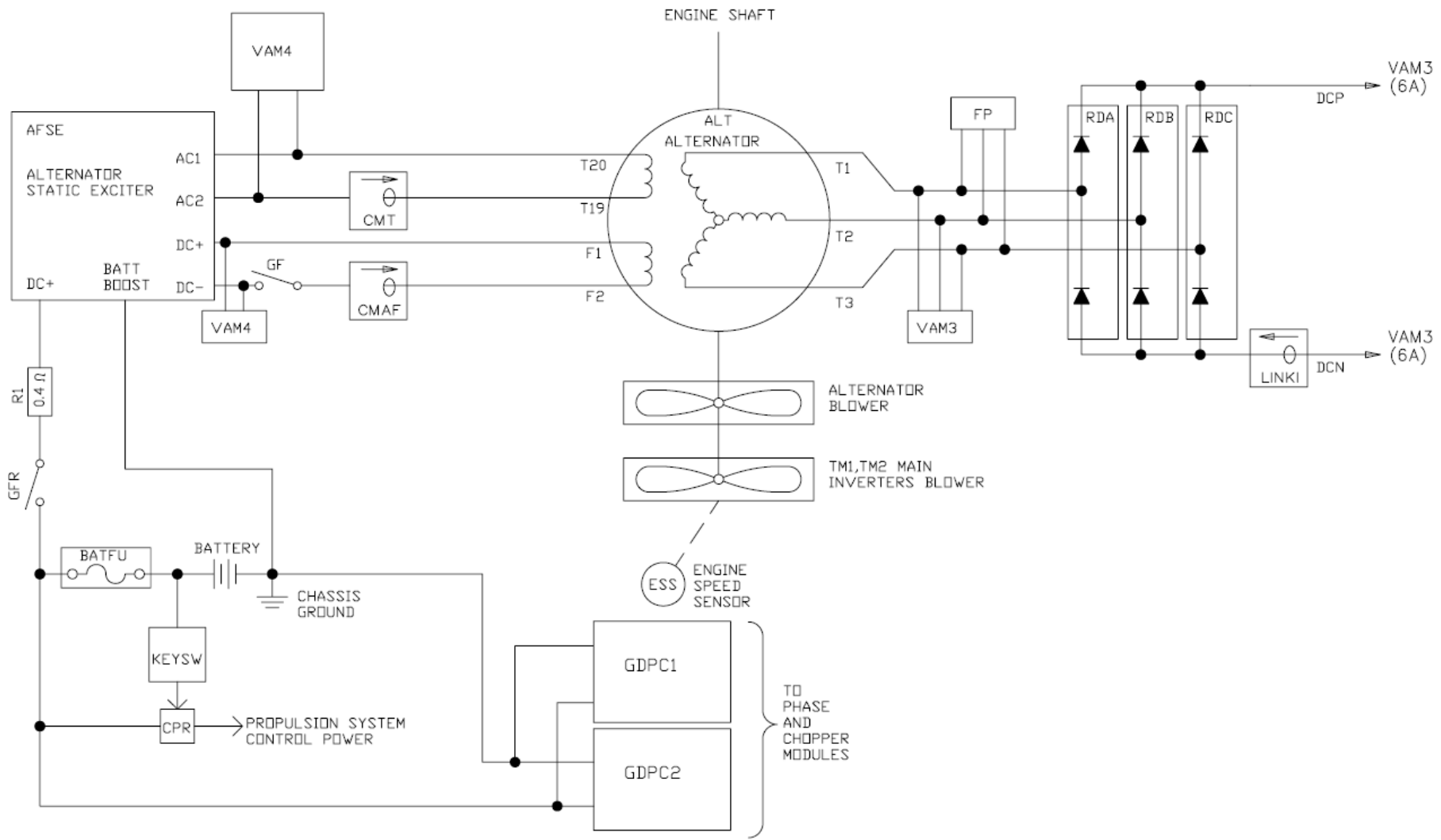

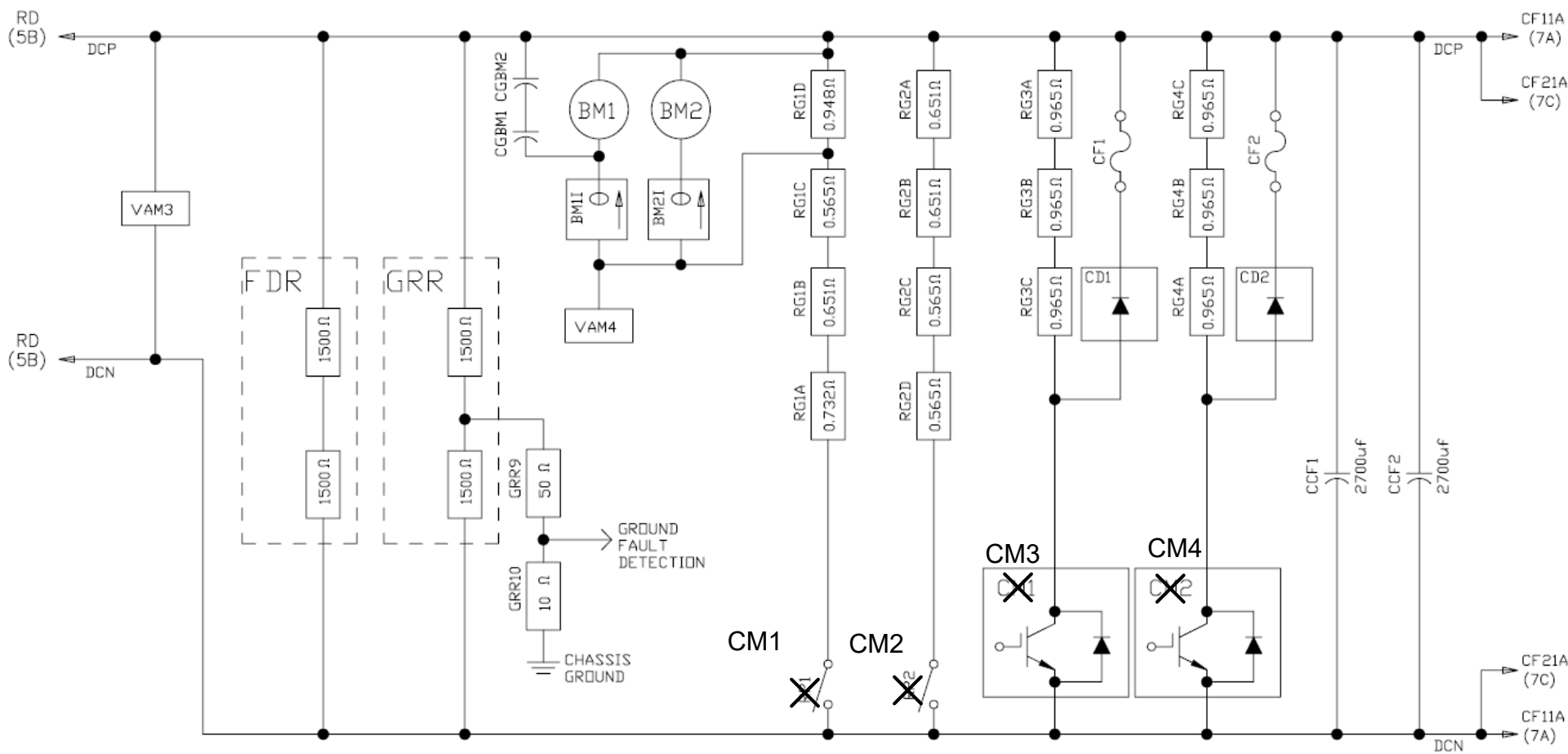

GRIDS REPRESENT 240AC HAULTRUCKS

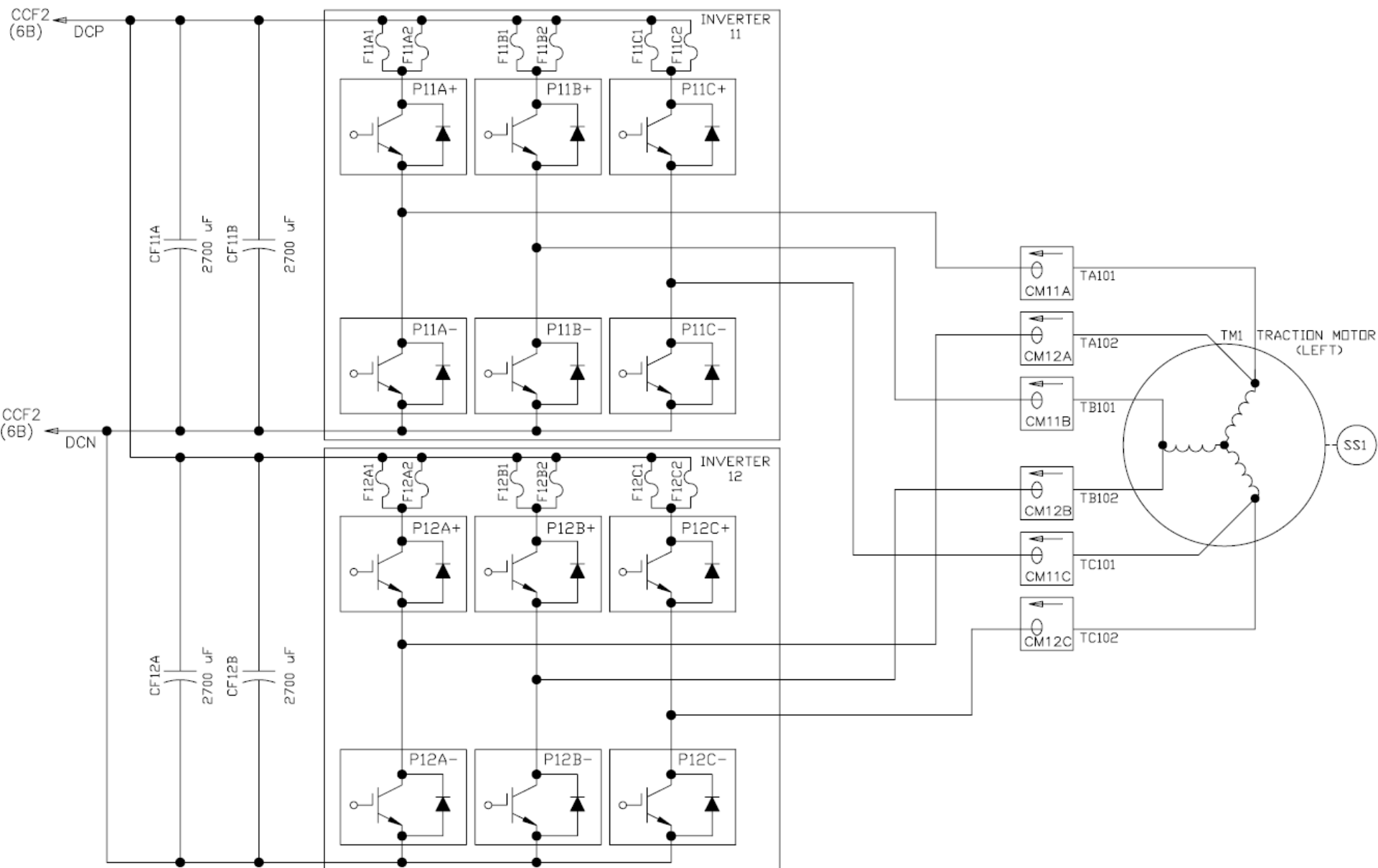

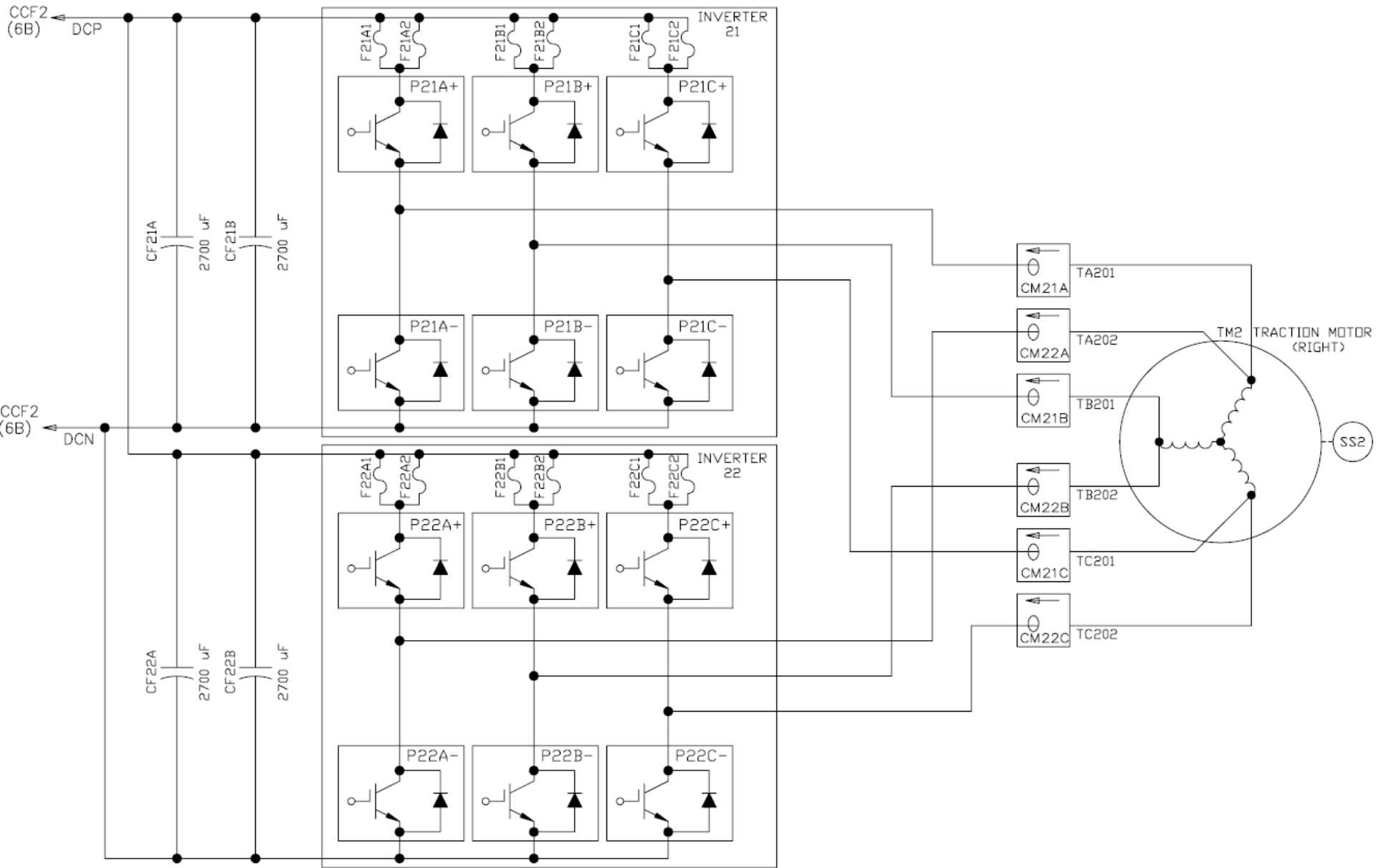

17KG535 Cabinet



(5)- 41A296332BLP15 Triangle Capacitor
Bus Bar

(5)- 41A296332BLP2 Vertical Bus Bar

Inverter Layout

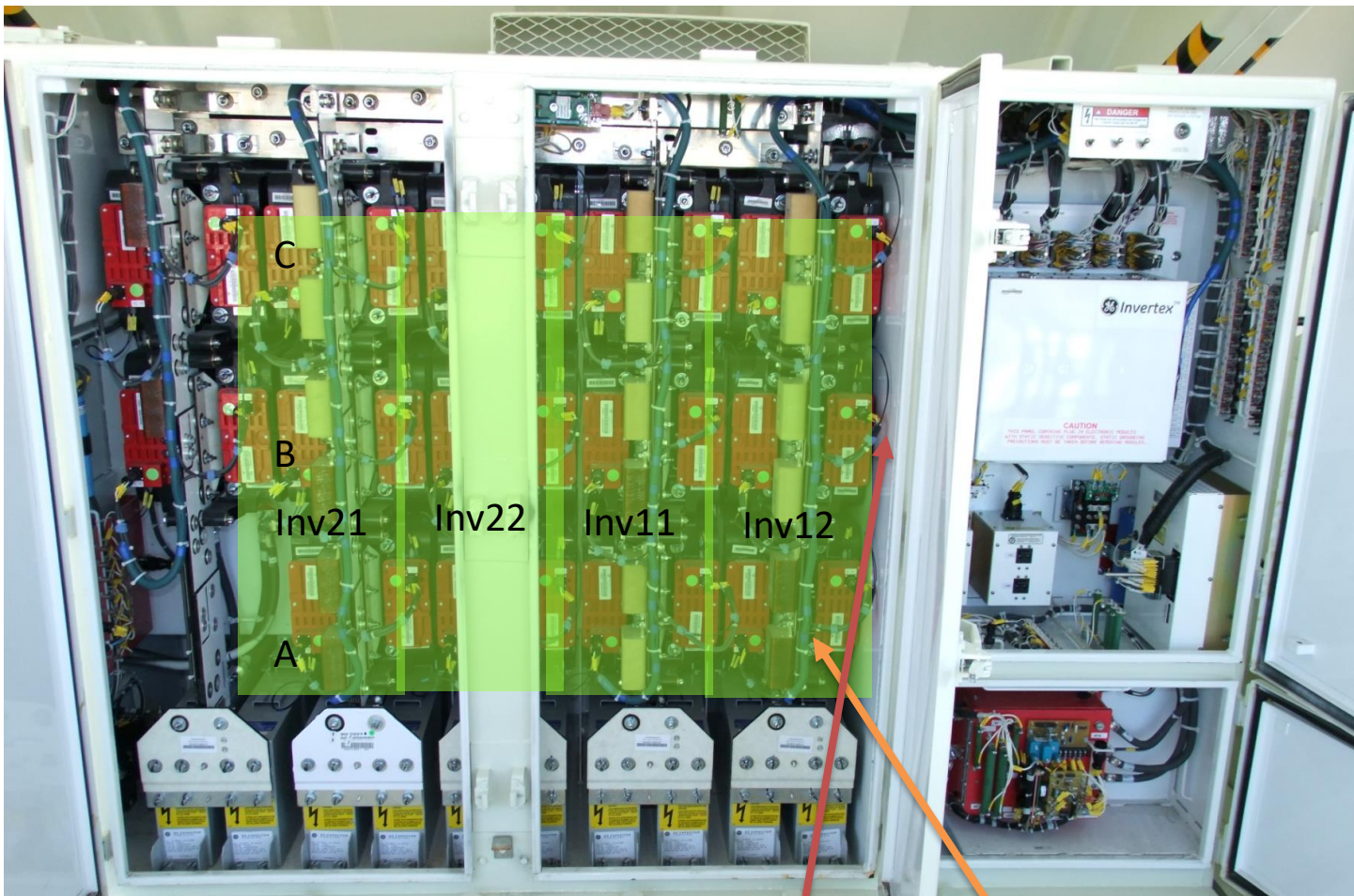

*84A214929ACG3
Gate Drive Power
Harness*

*84A214929ACG4
Fiber Optic
Harness*



SWITCH/LED PANEL

Figure 18

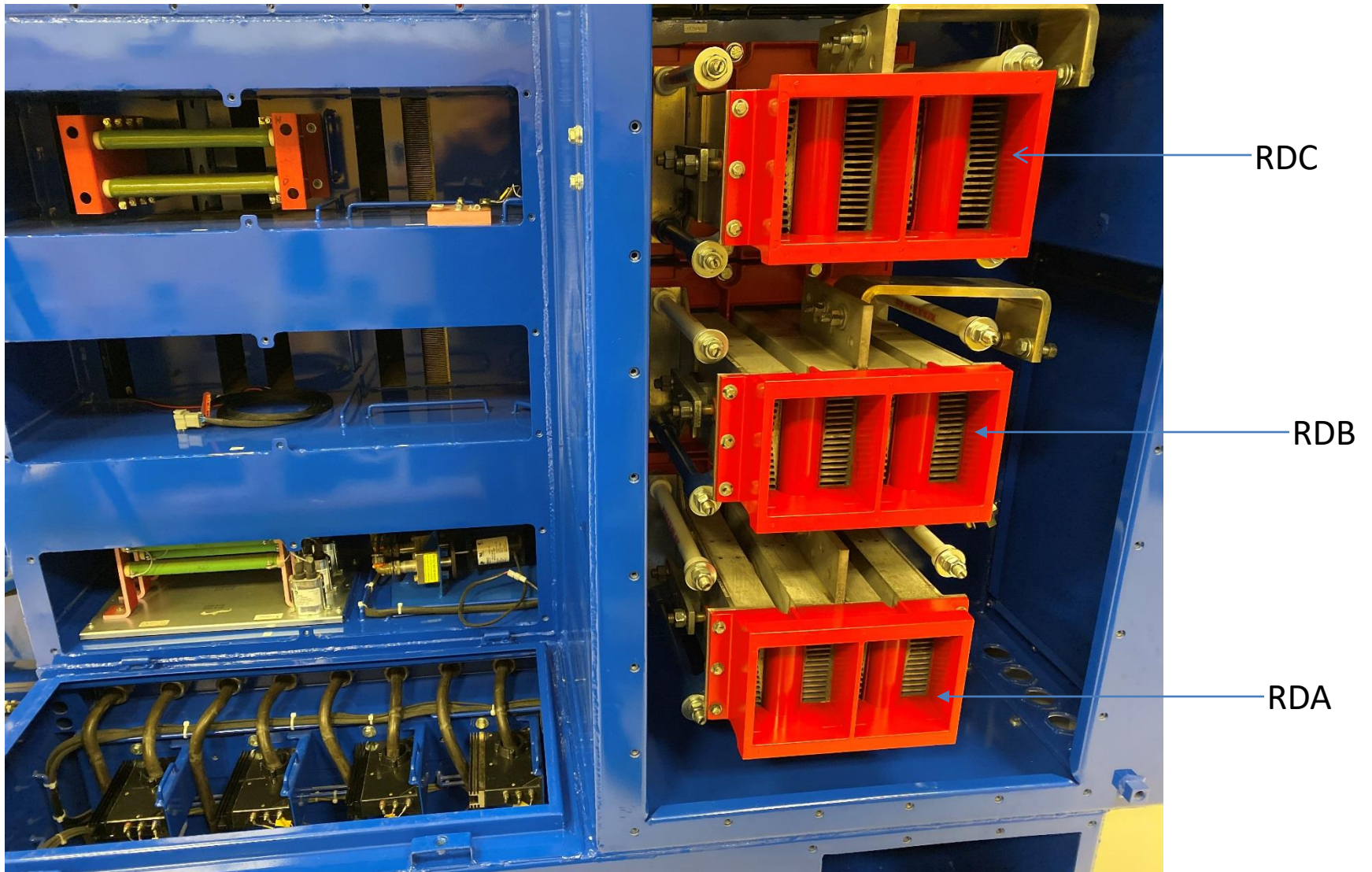

CONTROL GROUP - BACK

LEM Cabinet



CM12B

CM11A

CM11C

CM22B

CM21A

CM21C

CM12A

CM12C

CM11B

CM22A

CM22C

CM21B

41C663321G3 RP Contactor

41A296327ALP2 RP Contactor

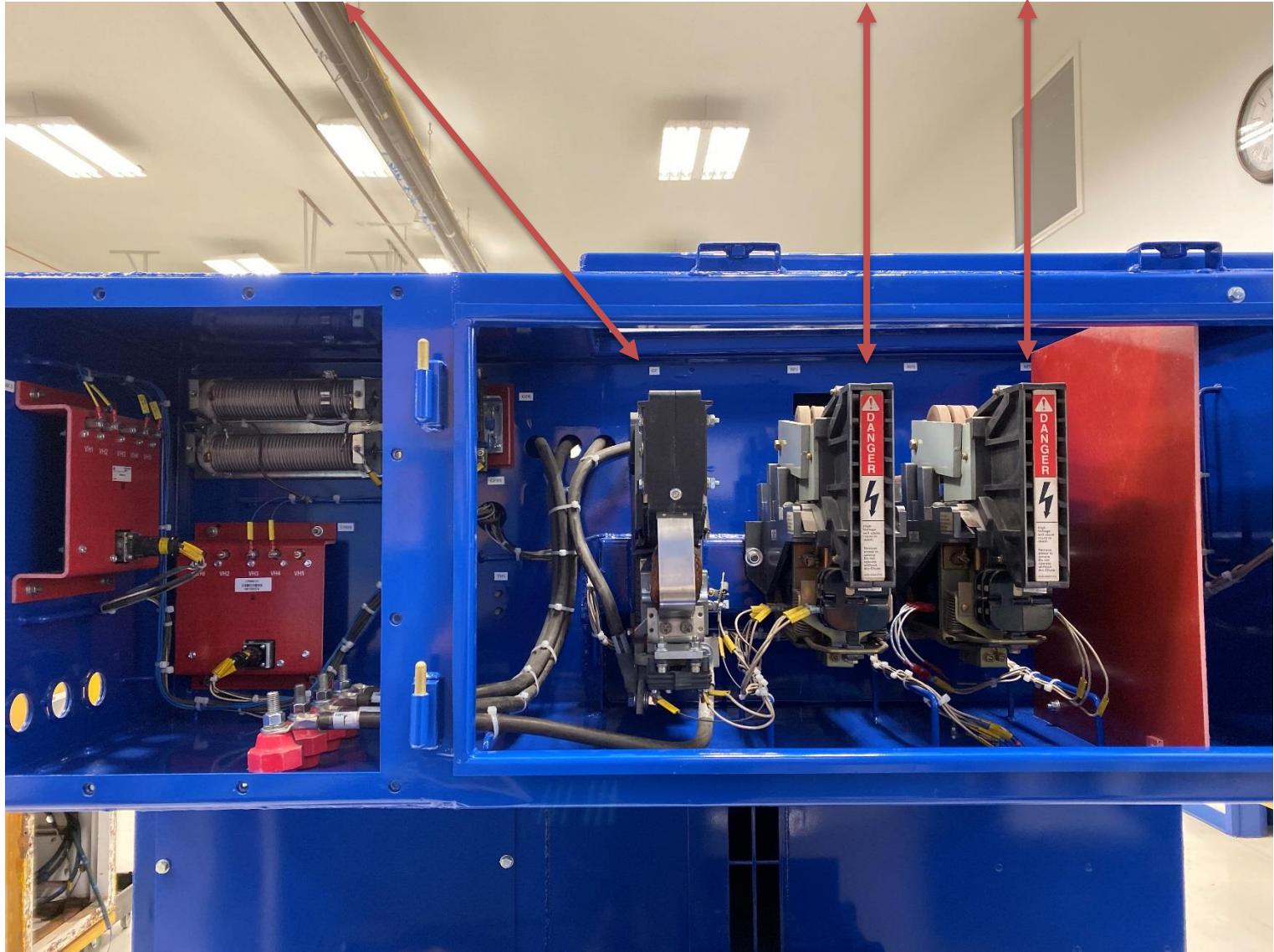

CONTACTOR GROUP IN CABINET



41A296327ALP2 RP CONTACTOR

Alternator Field Static Exciter (AFSE) 17FM689A1

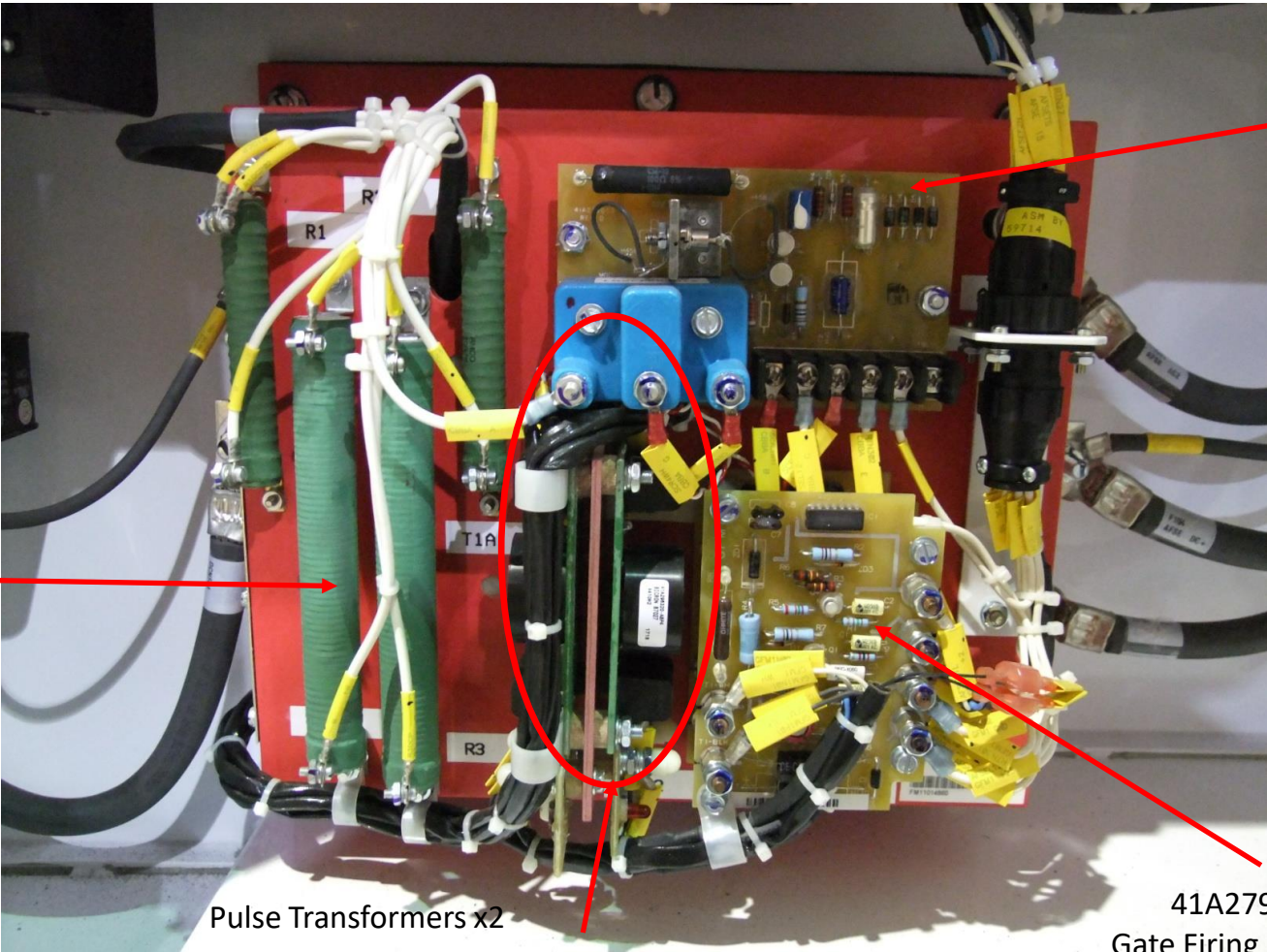

Snubber Resistors

41A278053G2
Battery Boost Card

Pulse Transformers x2

41A279579G1
Gate Firing Modules x2

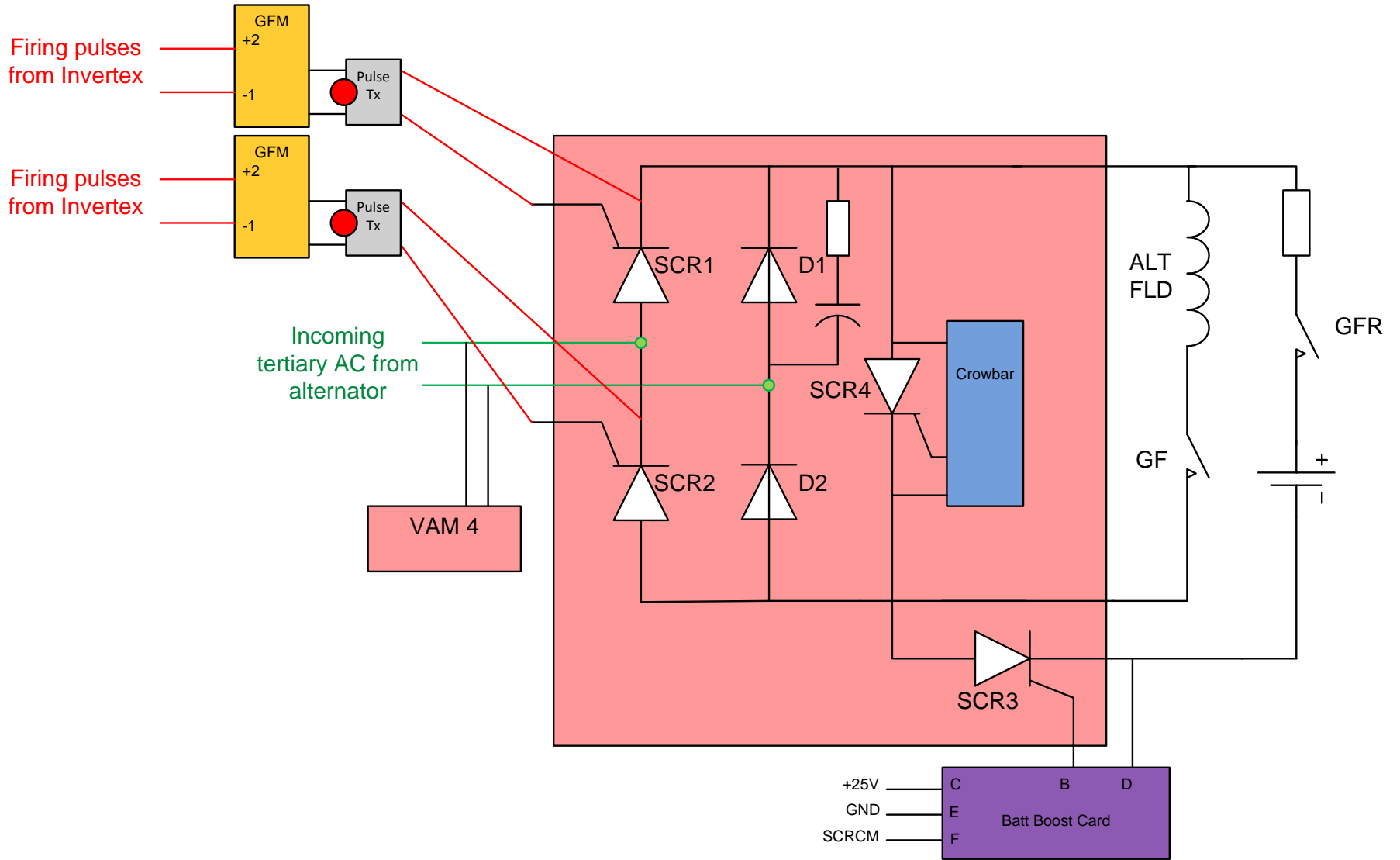

AFSE SCHEMATIC

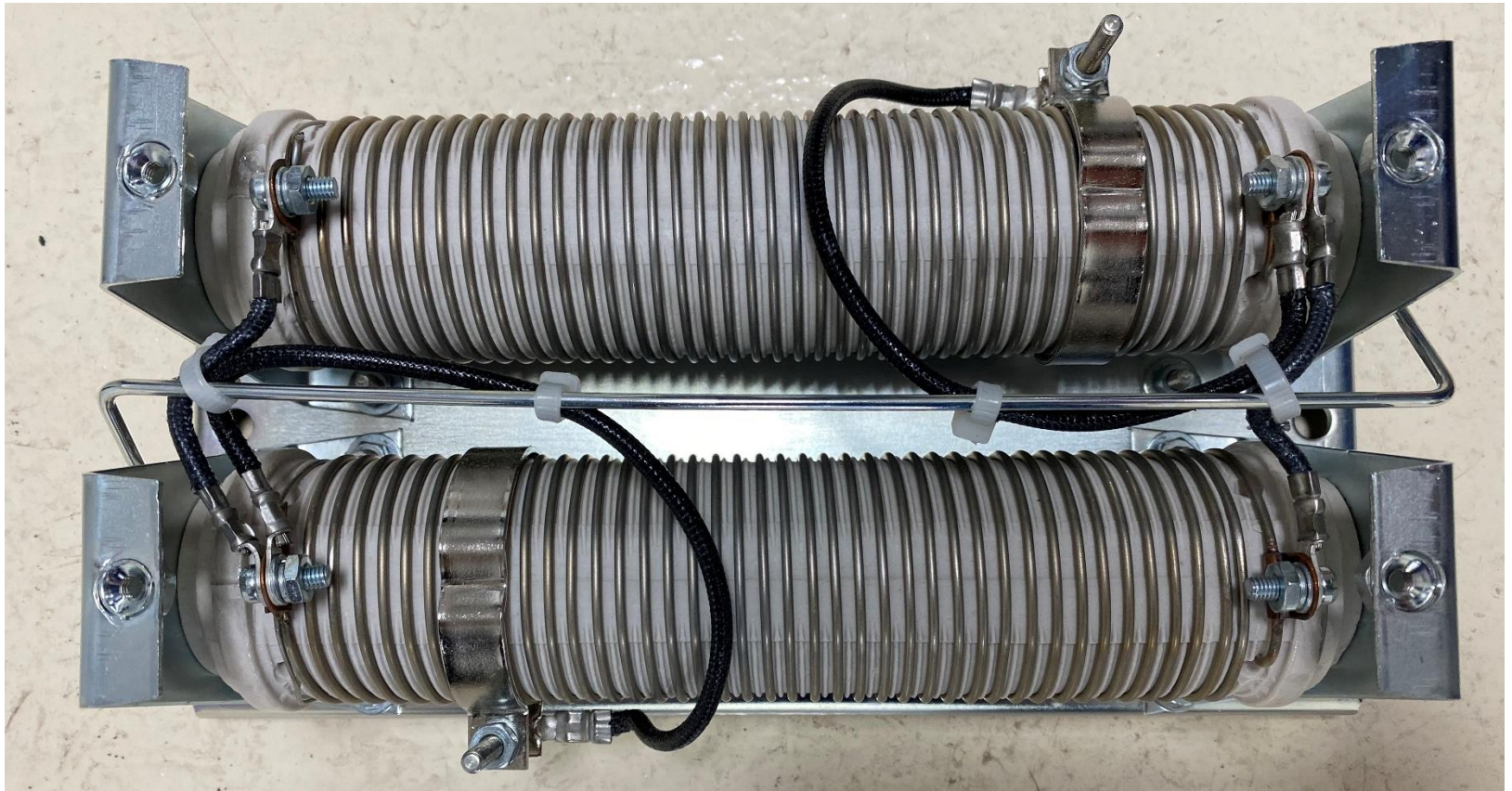

*R1 Battery Boost Resistor
17FR102*



17LV66J46 RELAY

SYSTEM COMPONENTS

MAIN ALTERNATOR

- Traction Alternator is a three phase, Y connected, AC generator.
- Intergrated blower for wheelmotors and control group.
- Tertiary windings for supply to AFSE & MFSE.
- Wound rotor used to vary output from alternator by varying rotor current.

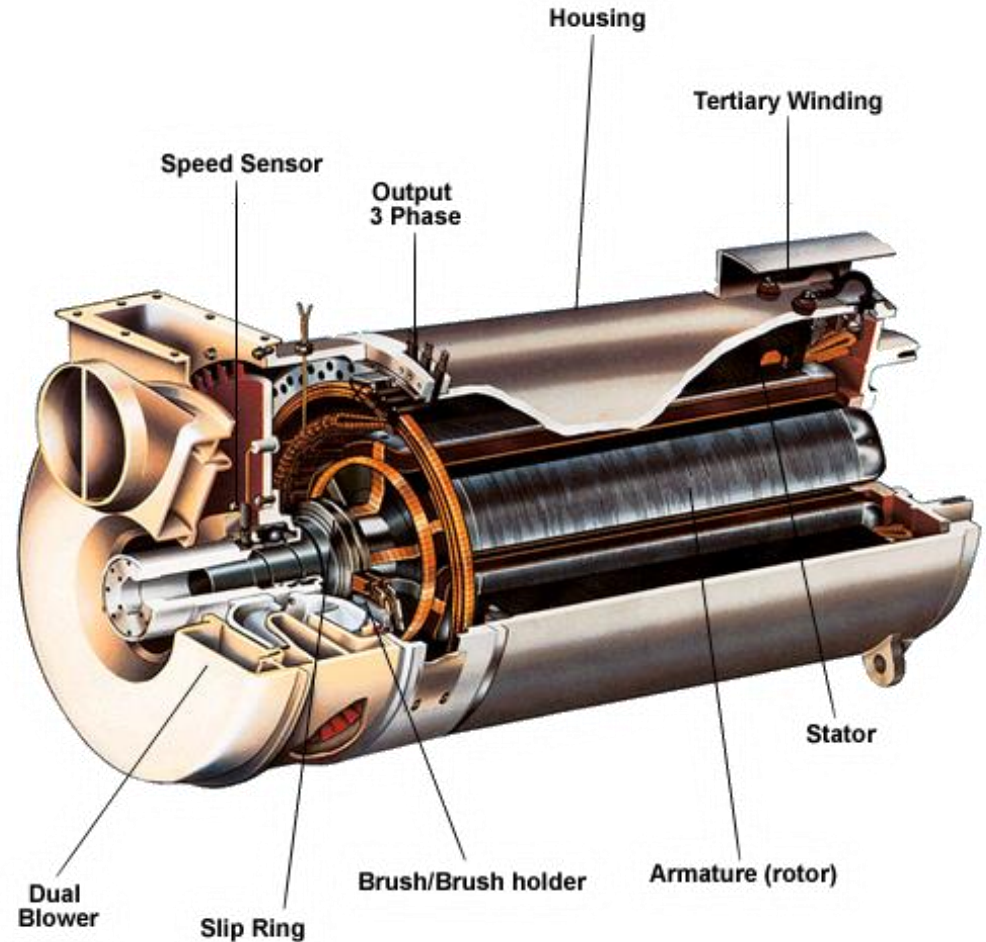

P/N'S- 5GTA41, 5GTA39, 5GTA49, 5GTA51

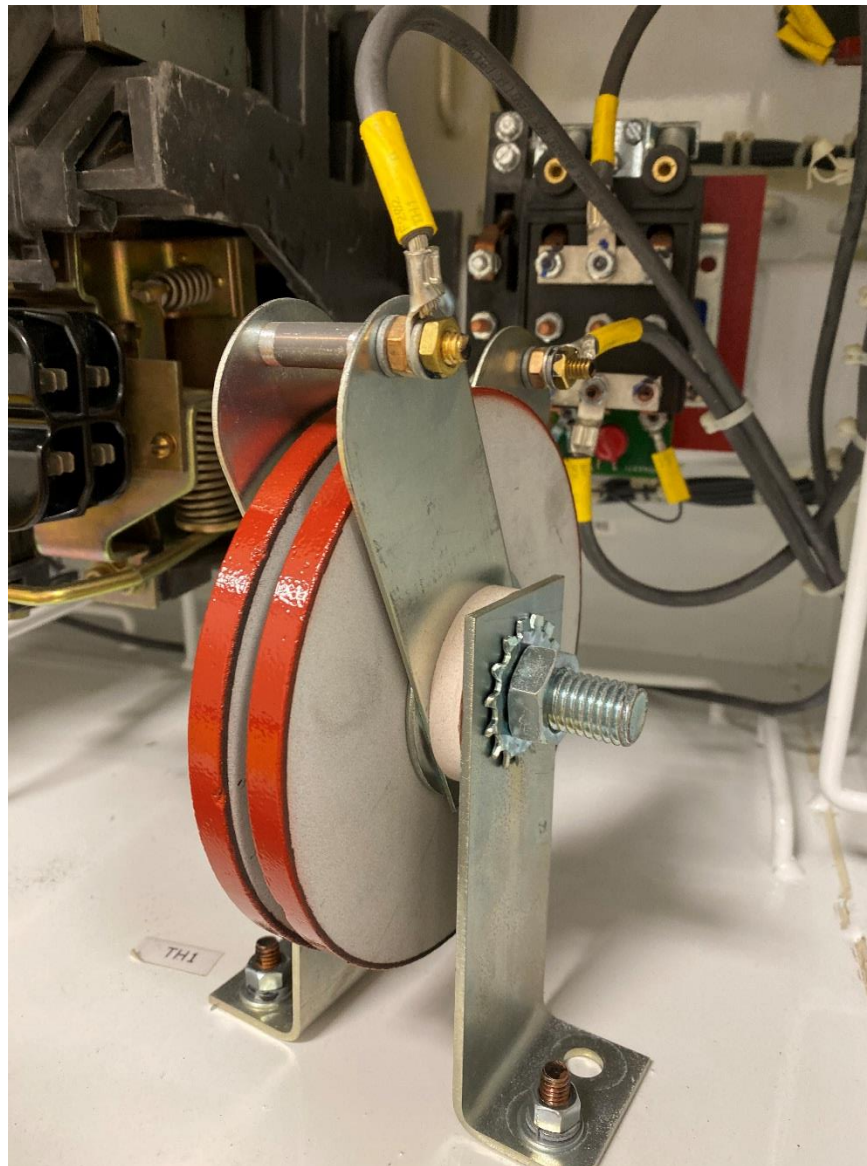

***ALTERNATOR FIELD DISCHARGE THYRITE (TH1)
41A259026P2***

Rectifier Panel

- There are 2 styles, until recently it was a large 3 piece unit (which has a higher KVA rating).
- Current production cabinet has now reverted back to the 'DC style' compact rectifier package.
- Both perform the same function and are the schematically the same.
- All are Three Phase Full Wave uncontrolled bridge rectifiers.

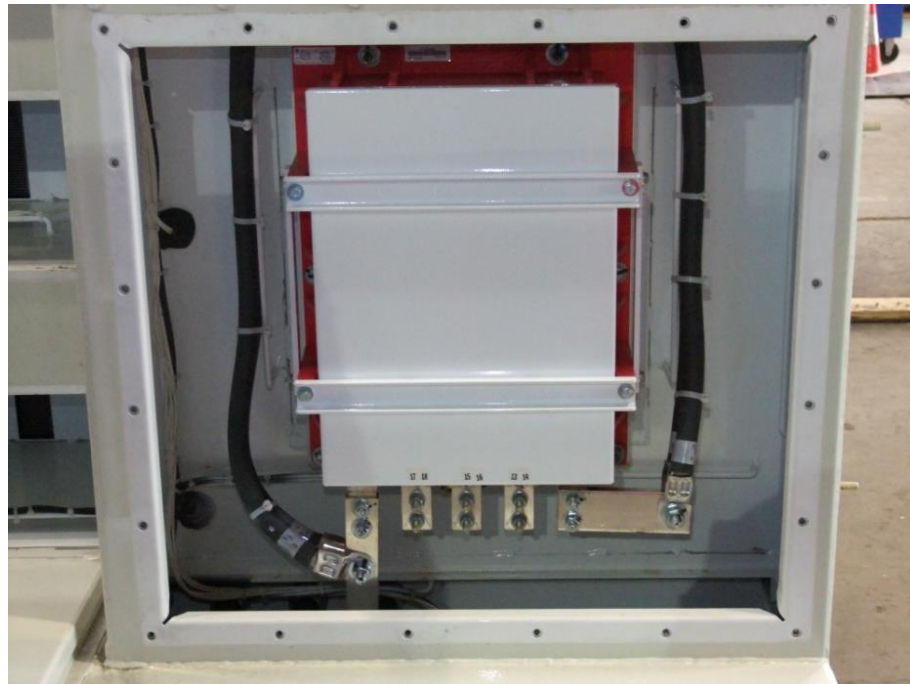

(1) 17FM528A1 Rectifier

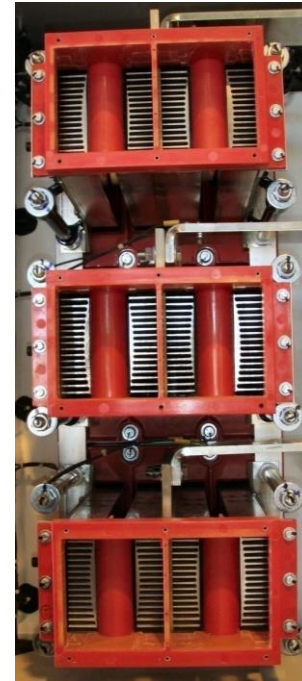

(3) 17FM792A1 Rectifier

Rectifier Schematic

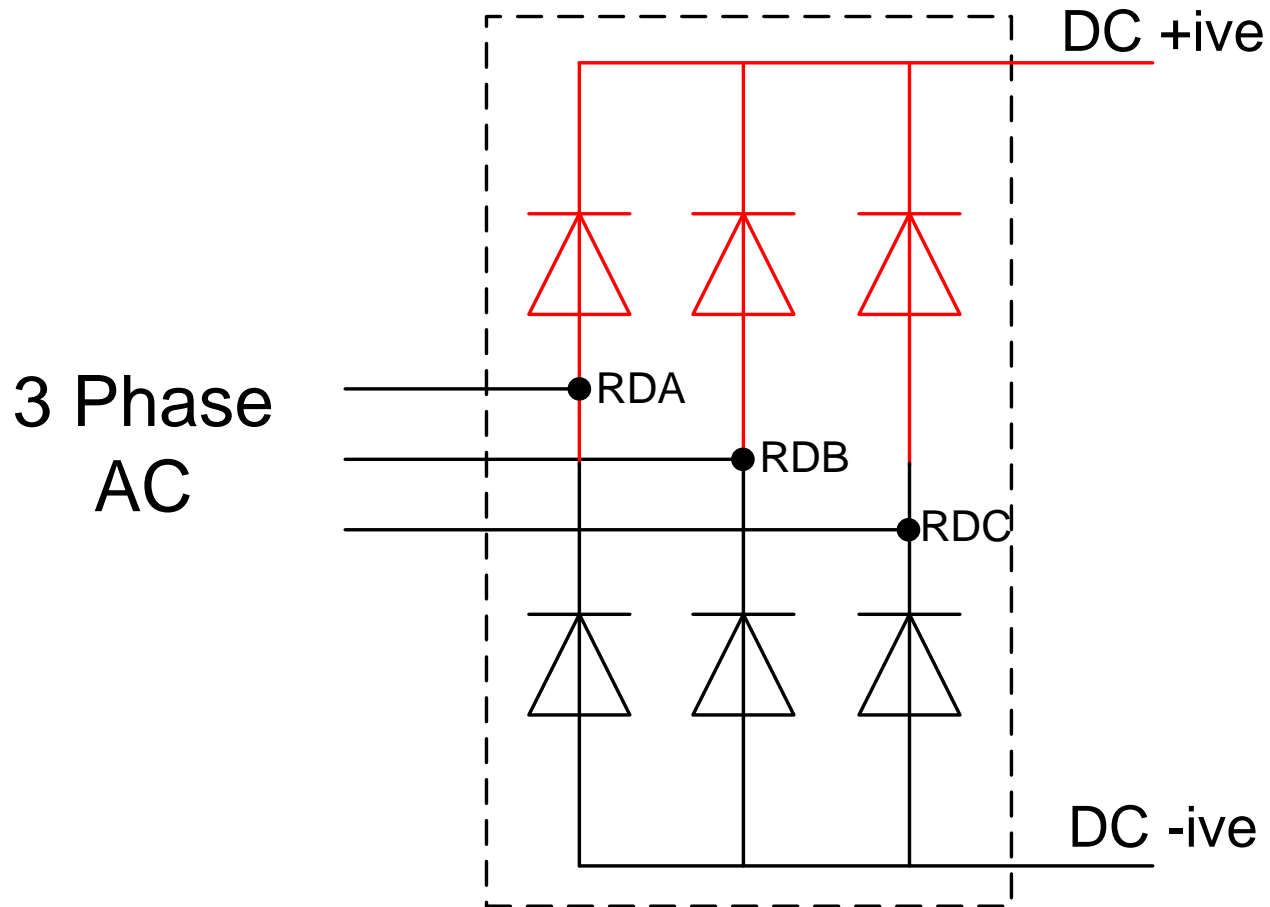



41C662412G2 Alternator Filter Panel

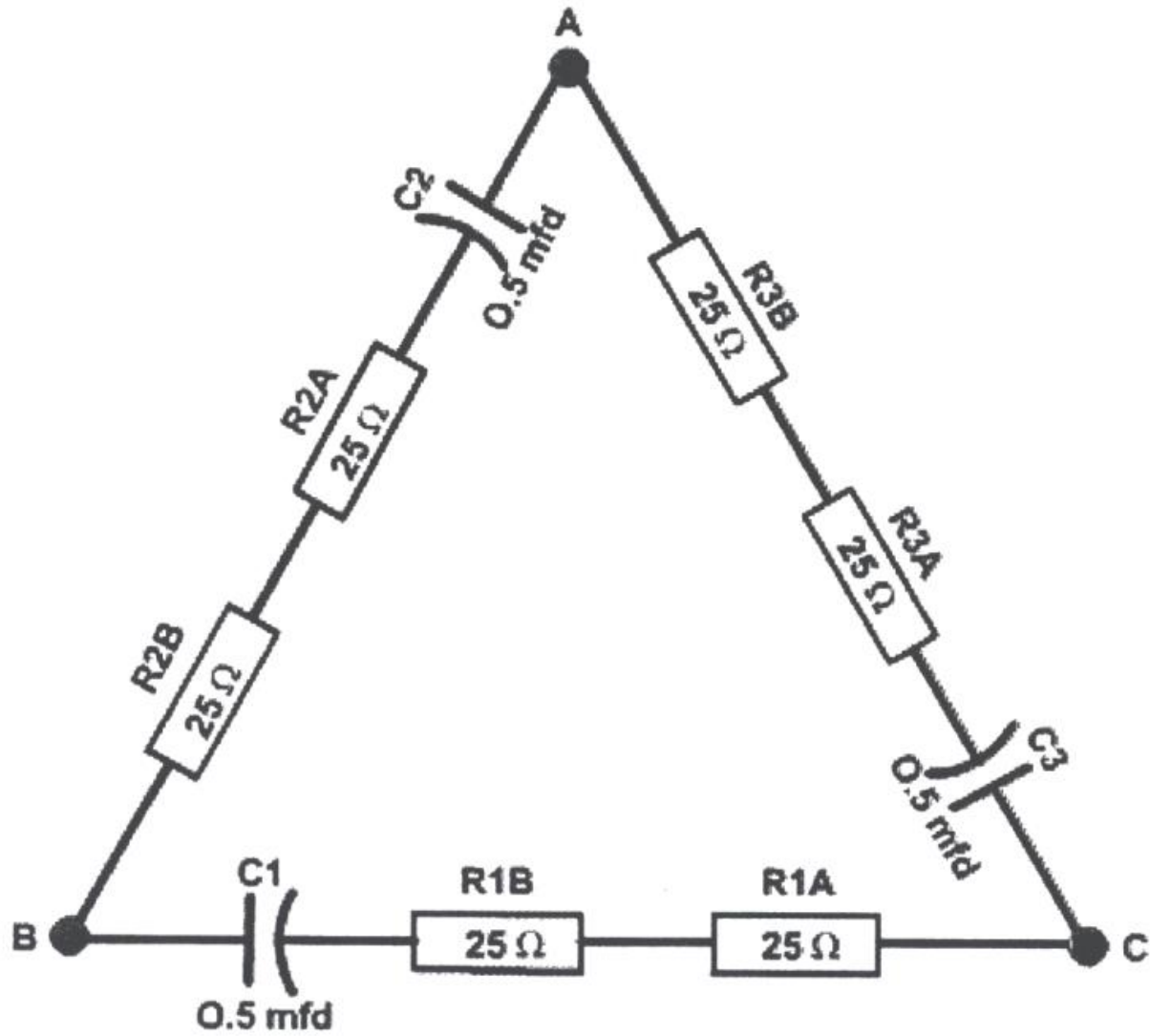

FILTER PANEL SCHEMATIC



17FM402A1 GROUND REFERENCE RESISTOR PANEL

Ground Fault Protection Circuit

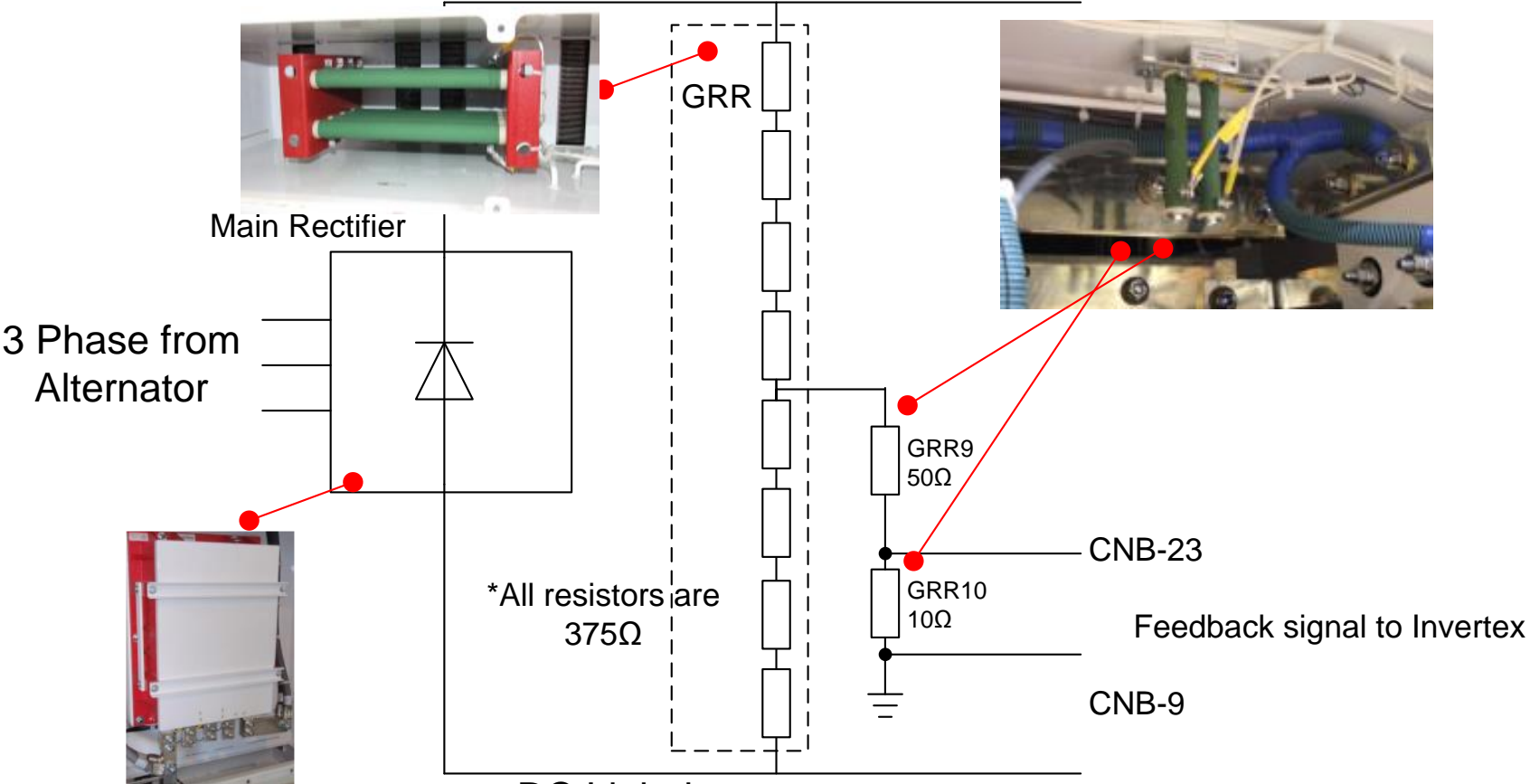

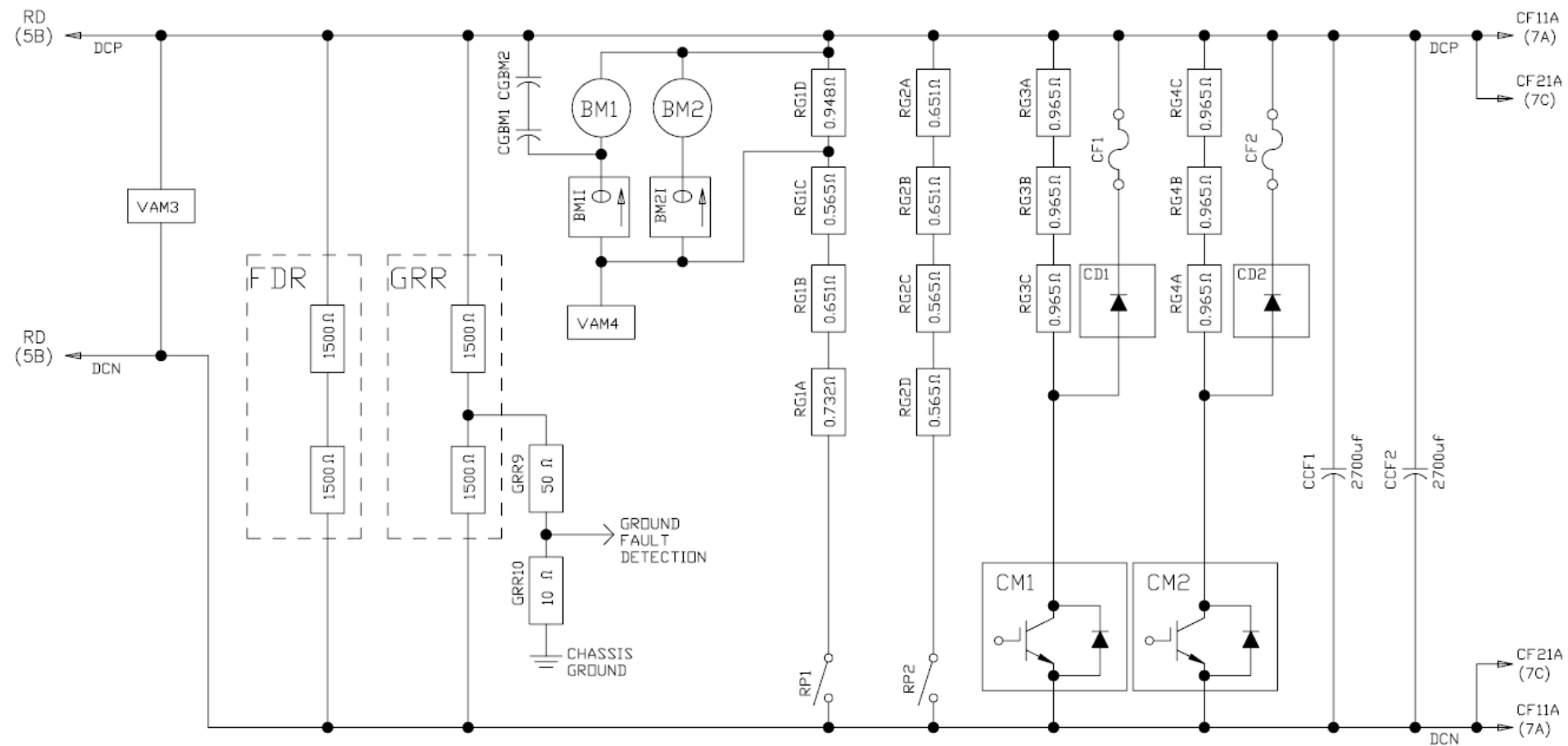

240 GRID BOX

- (1)- 17EA33J732
- (3)- 17EA33J651
- (3)- 17EA33J565
- (6)- 17EA33J965
- (1)- 17EA33J945

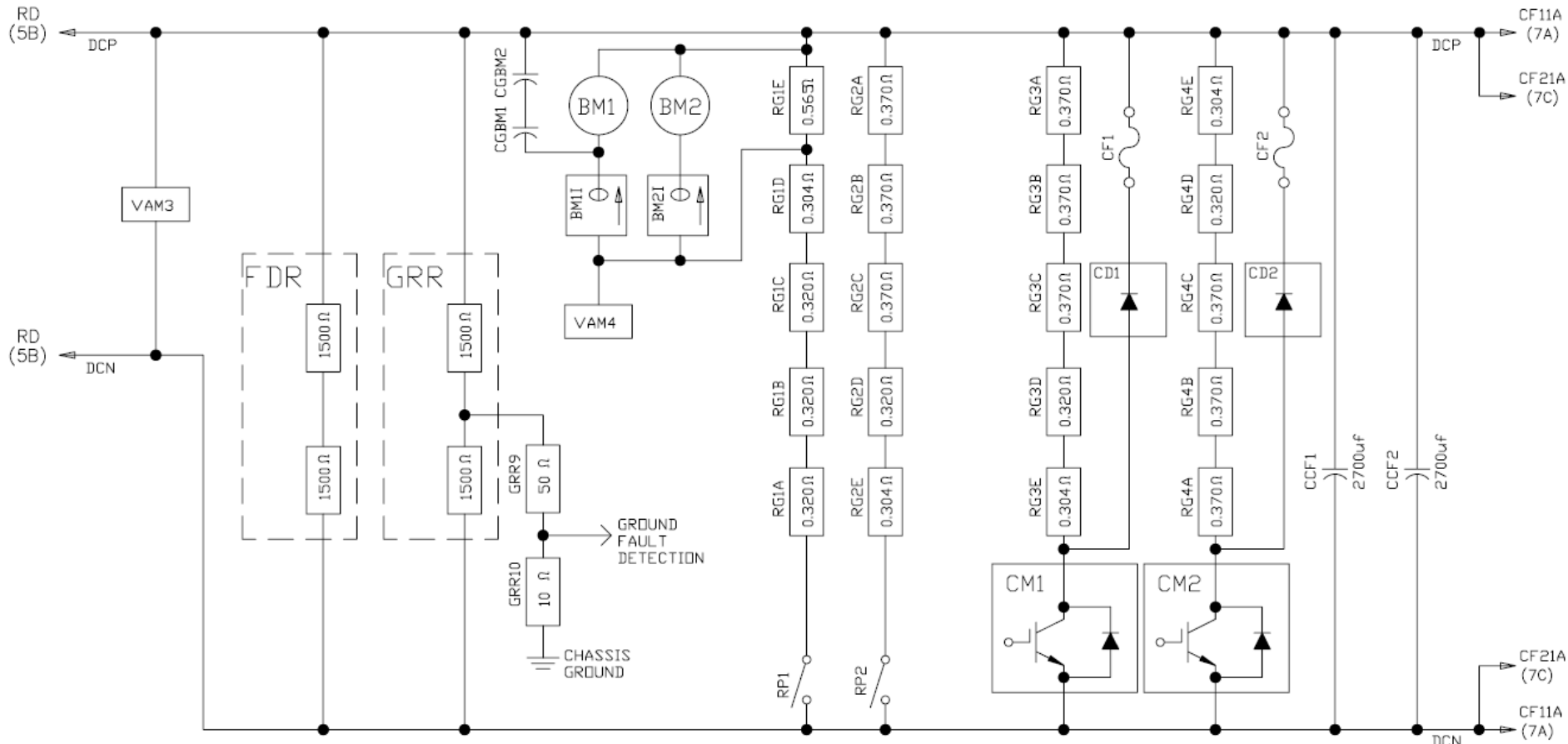

320 GRID BOX

- (6)- 17EA33J320
- (4)- 17EA33J304
- (1)- 17EA33J565
- (9)- 17EA33J370



17EM145- (830E-AC) – 14 Grid Resistors

17EM146- (TEREX MT4400 AC) – 14 Grid Resistors

17EM136- (930E-4) – 20 Grid Resistors

17EM140- (960E-1) – 23 Grid Resistors



5GY19L6, 5GY19L7, 5GY19L8

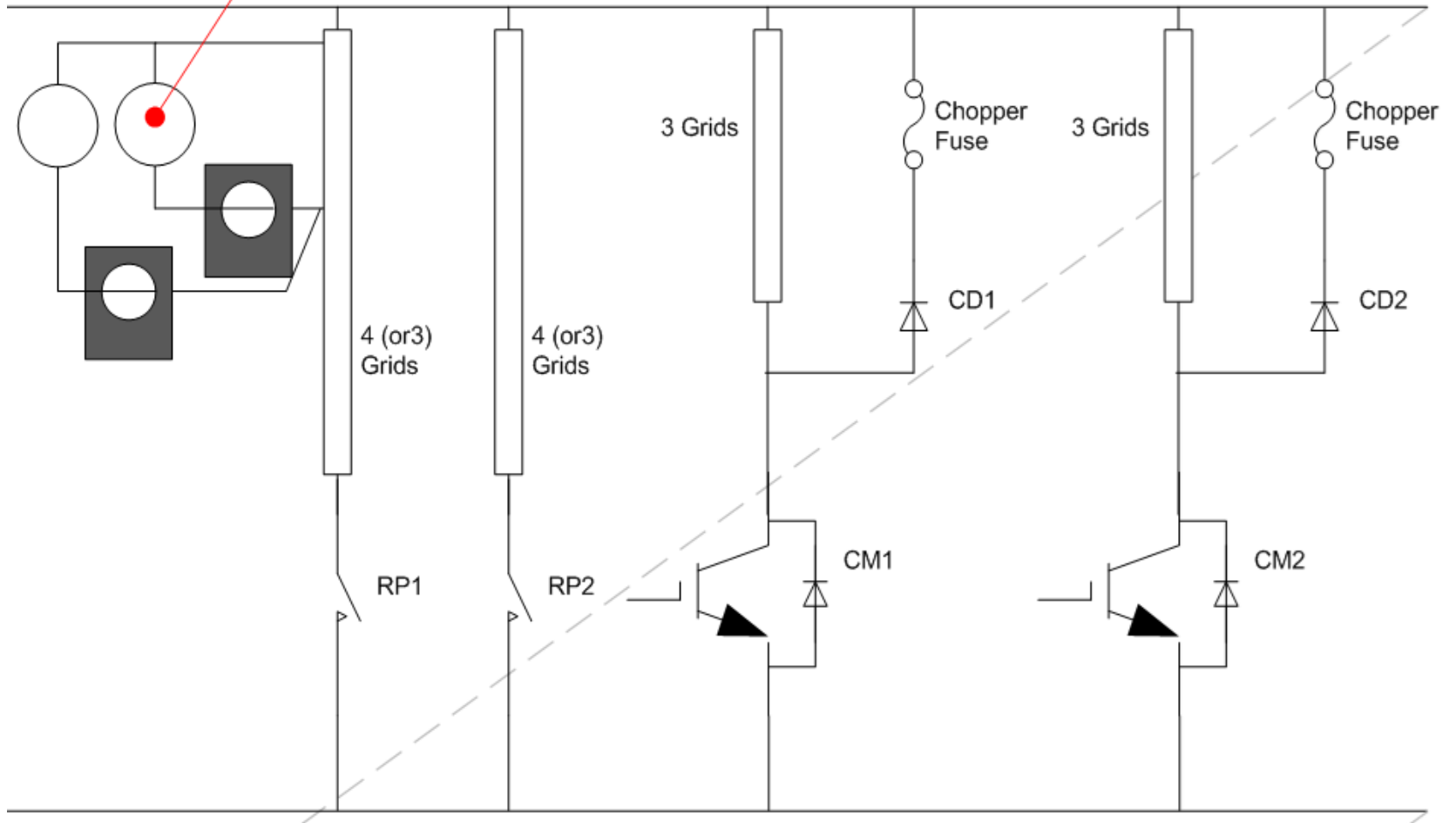

Retarding Grids



Grid Resistors per package

New “J” Style as standard

Usual mix and match precautions

(multi types of resistance)

Grid Part Numbers are 17EA33J***

The Resistance Value of the Grid Makes up the last part of the part number.

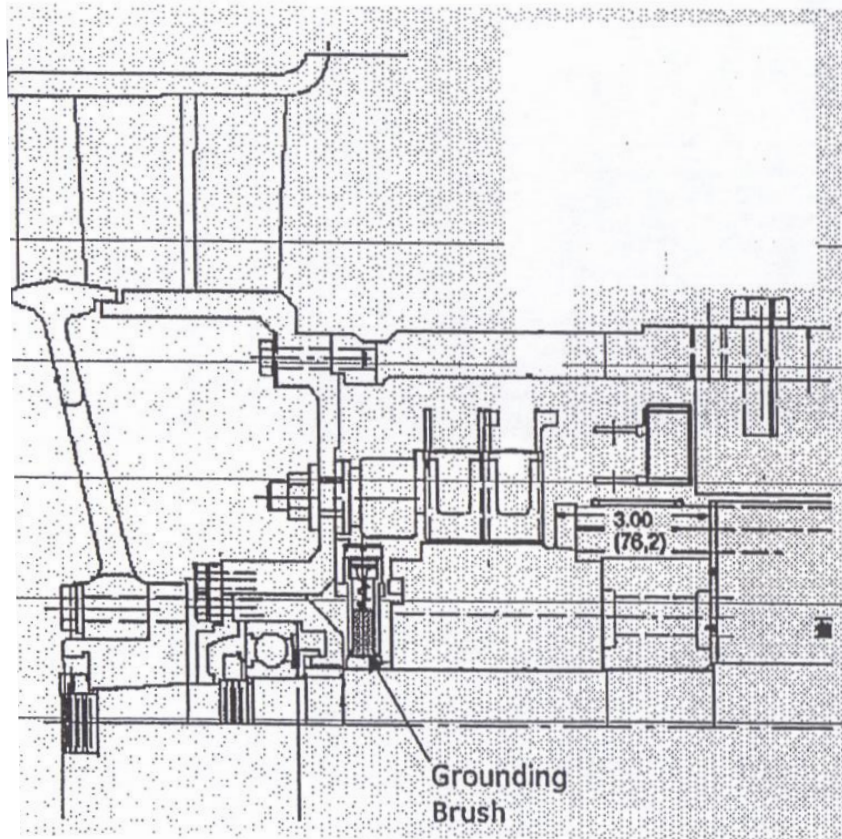

Note: 2 x Blower Motors (5GY19L6). Blower motor now includes a shaft grounding brush.

DC Link Capacitor

41A296302CDP2 2700uf

41A296302CDP6 2250uf



41A296332BLP15
Triangle Bus Bars



Cracked connection, test for
Capacitor being charged



Positive Phase Module (17FM796)

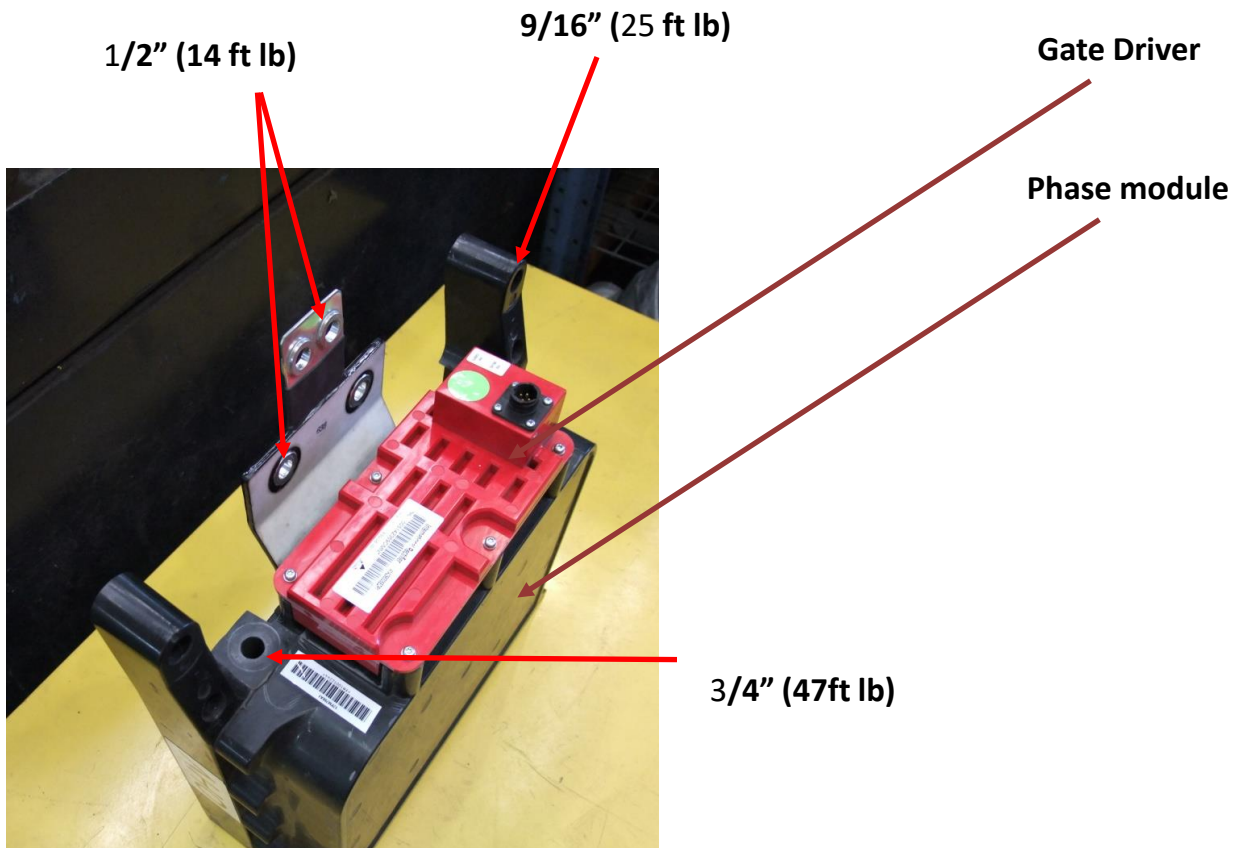

Negative Phase Module (17FM797)

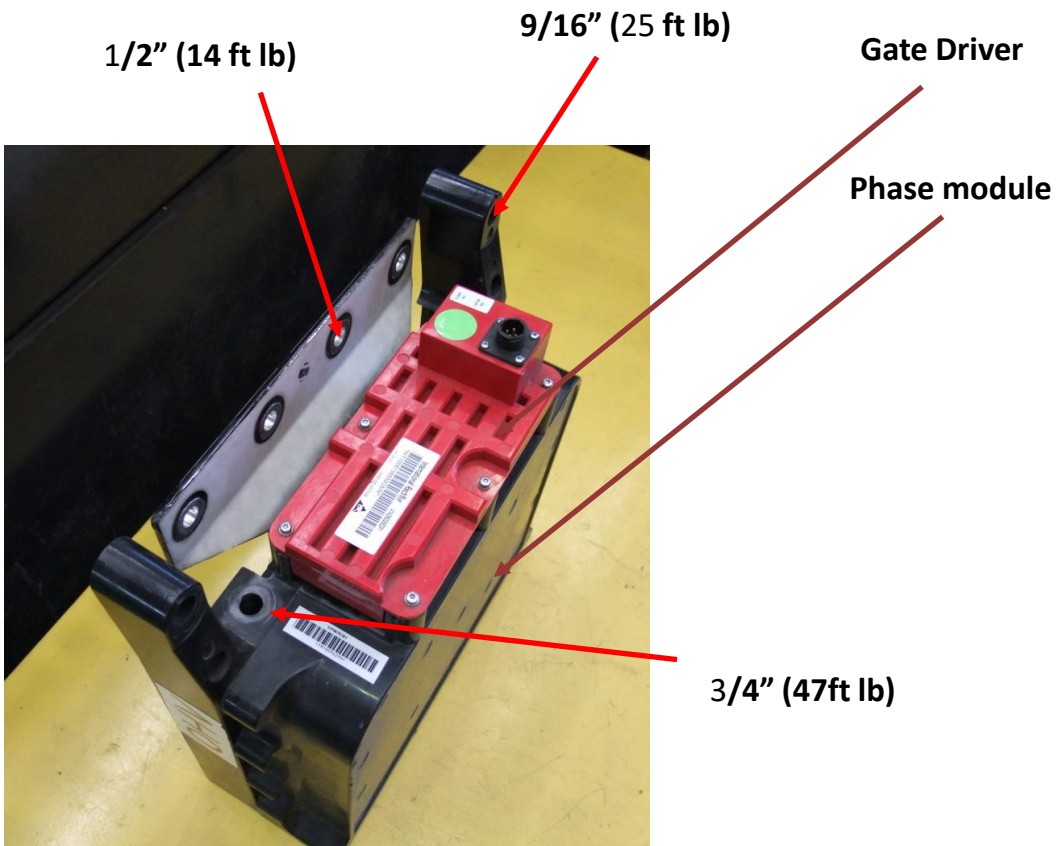

Phase Fuse

41A296321BSP2

General Electric Recommends these to be changed in matched pairs



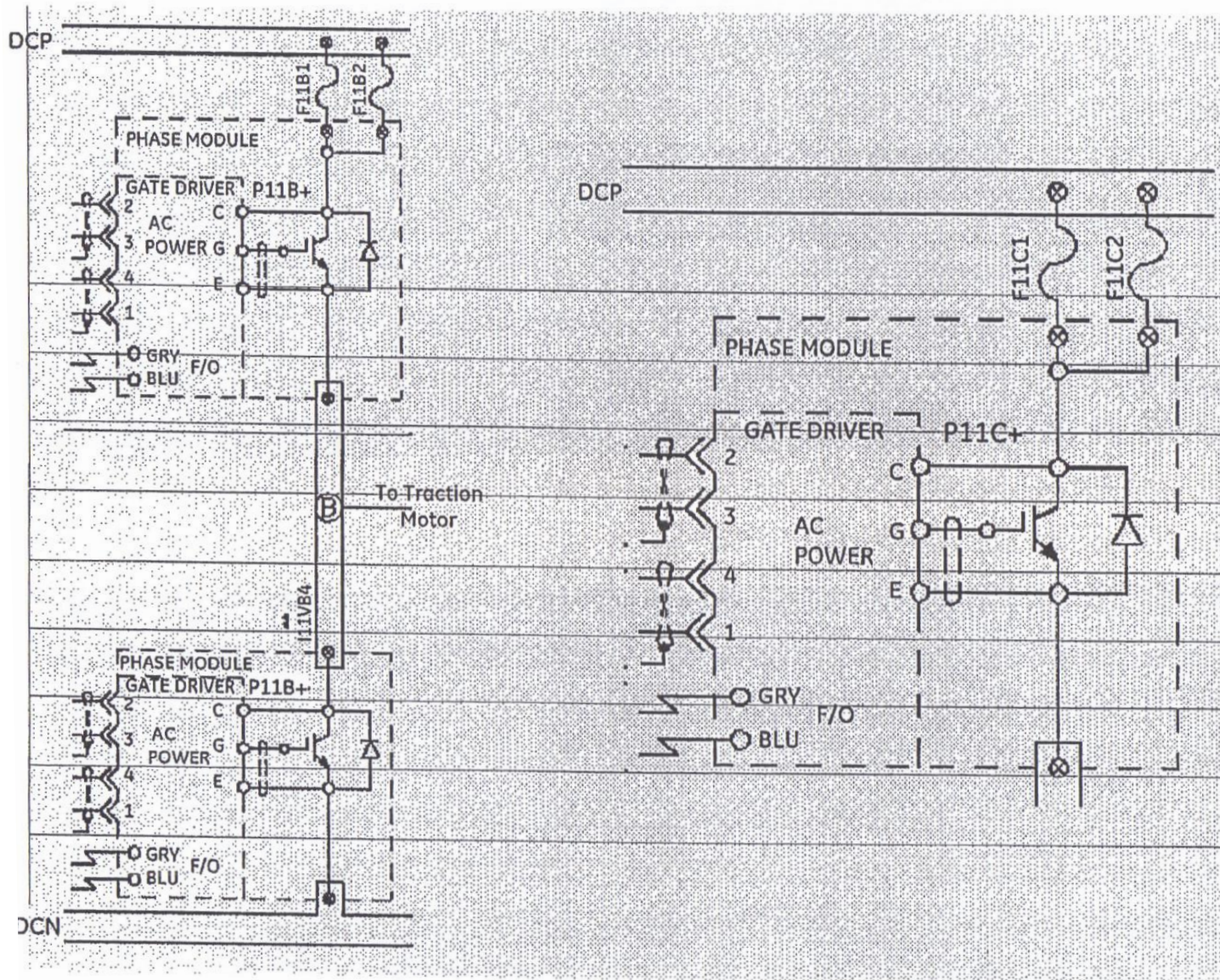

PHASE MODULE CONNECTIONS

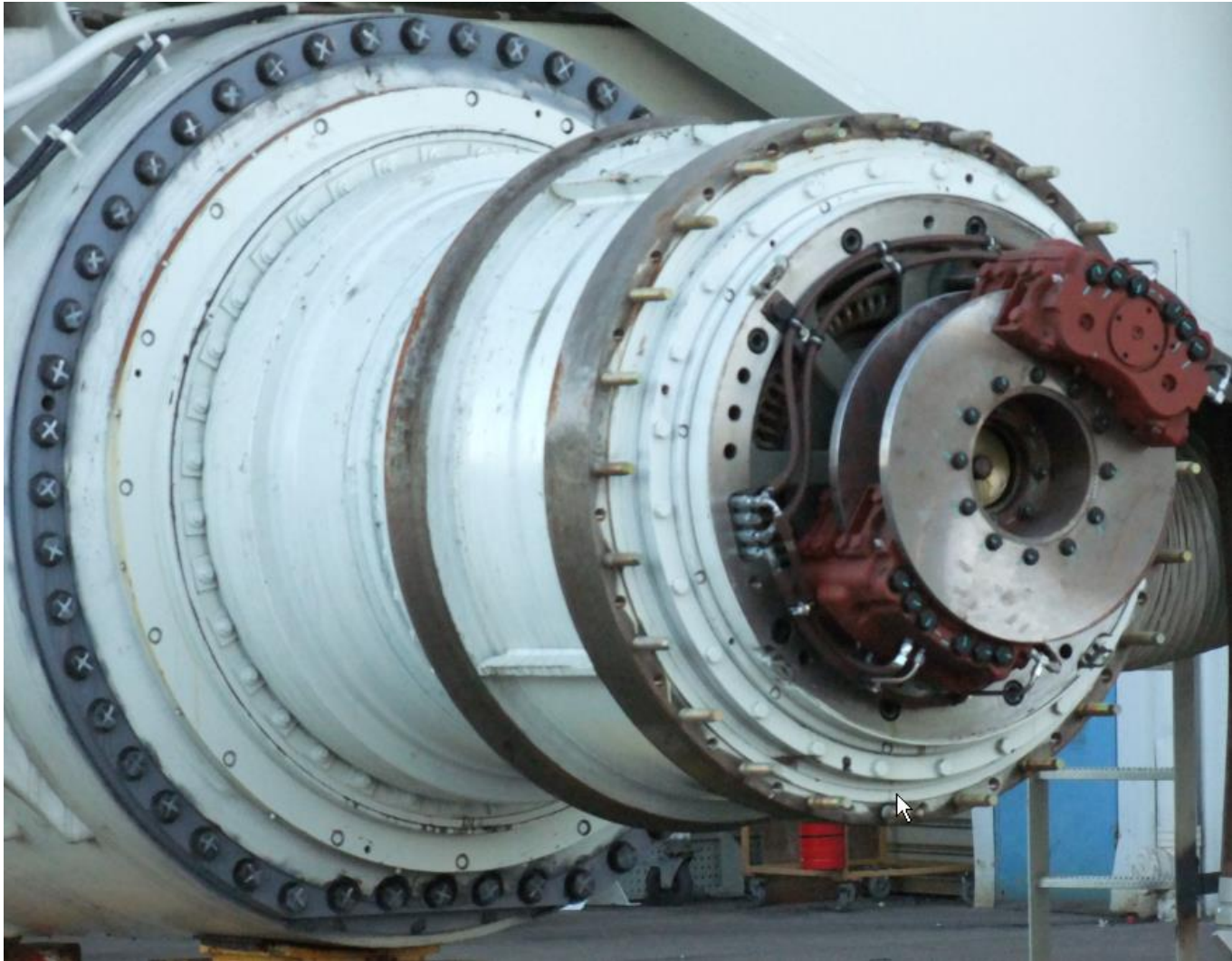

GEB25 Wheel Motor

GE250AC™ Drive System



Motorized AC Wheel - 5GEB36

- Based on proven GE787DC wheel and GEB 13AC Freight locomotive traction motor
- Designed for >20,000 hours MTBO at nominal 890,000 lbs GVW
- Continuous motoring capability up to 12% equivalent grade
- Standard mounting arrangement for 50/80R57 tires

ratio 31.875 : 1

40 mph/3340 rpm

Propel 1050 Hp

Retard 2150 Hp max

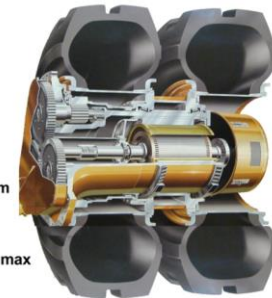

AC Training Manual

Off-Highway Vehicles

17KG551 Control Group

One Team Dedicated to Customer Success . . . Worldwide™

GE320AC™ Drive System



Motorized AC Wheels – 5GDY106

- Designed for 24,000 hours MTBO at nominal 1,120,000 GVW
- Removable inboard thrust washer - easier maintenance
- Mount 53/80R63 tires

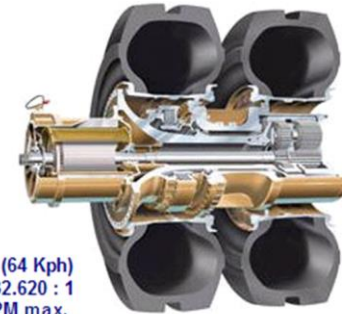

40 Mph (64 Kph)
Ratio 32.620 : 1
3340 RPM max.
Propel 1400 HP
Retard 2650 max.

GE Transportation Systems

41A328039EBP4 240AC
41A296328BFP8 320AC/360AC

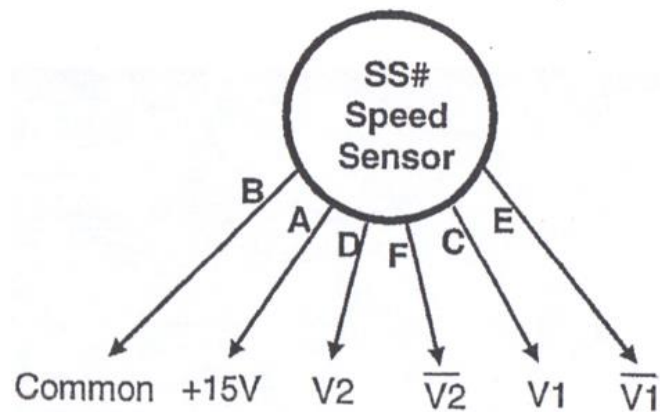
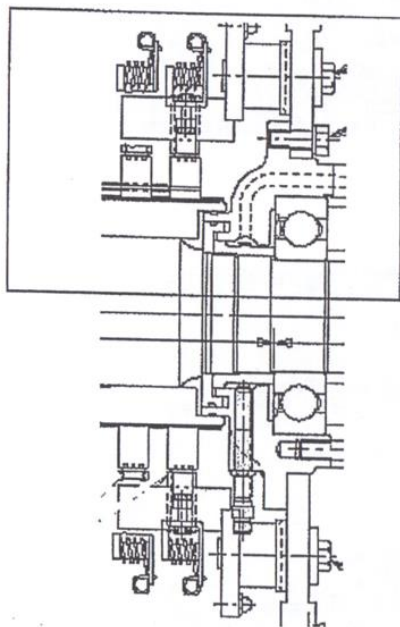
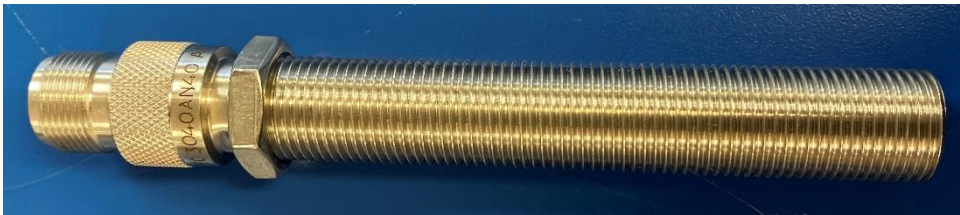

SPEED SENSORS

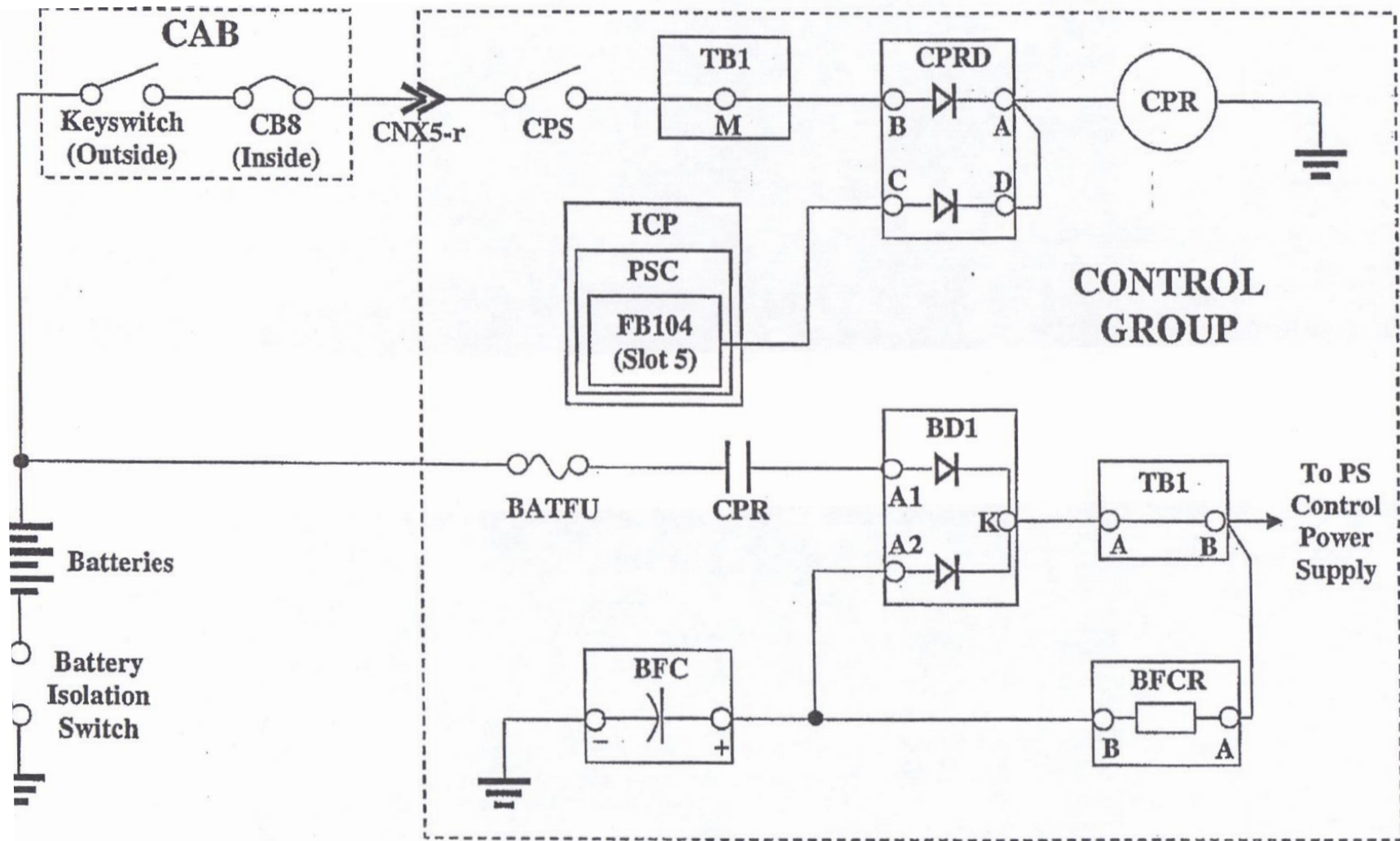

TEREX BATTERY CONTROL POWER

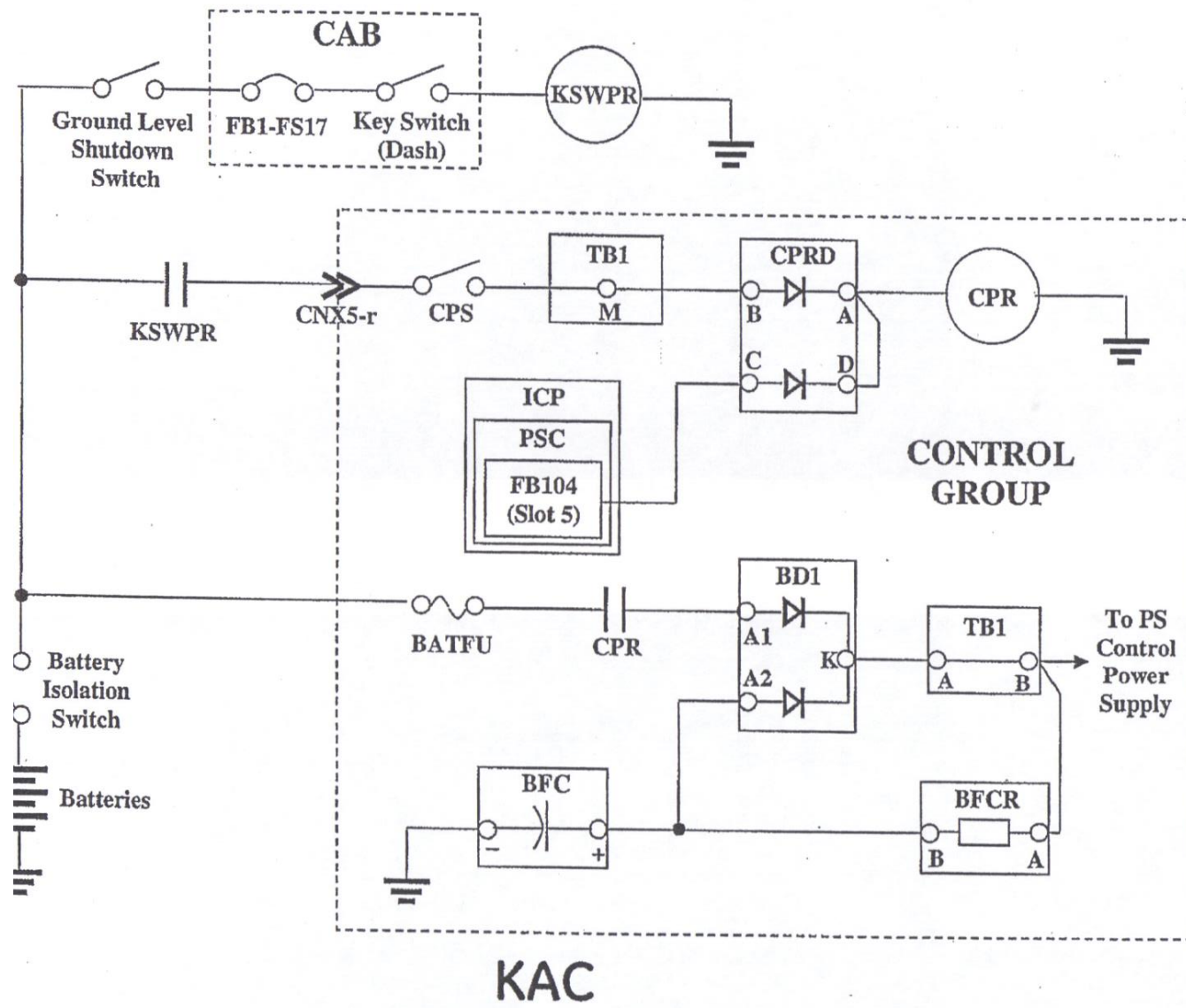

BATTERY CONTROL POWER

Figure 58

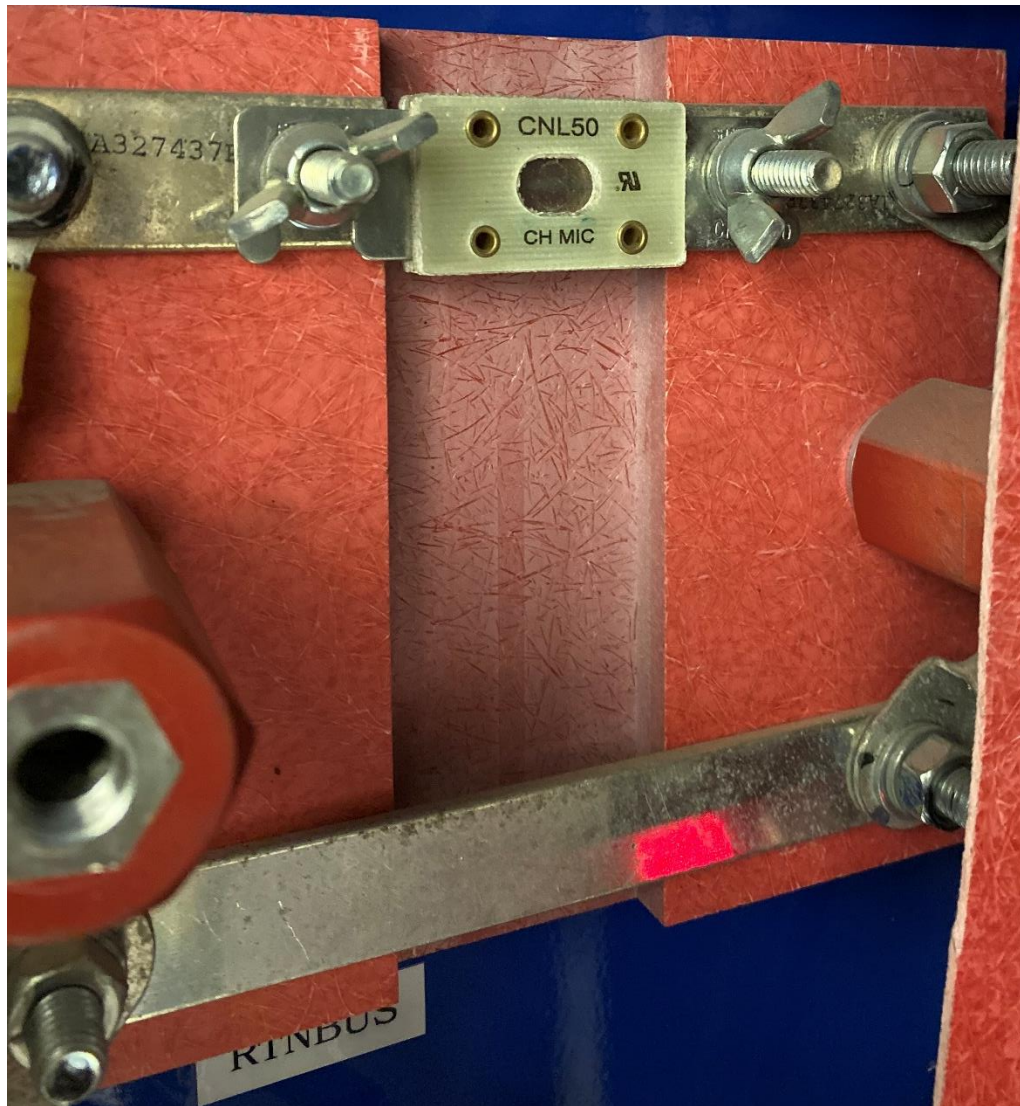

Battery Fuse Panel

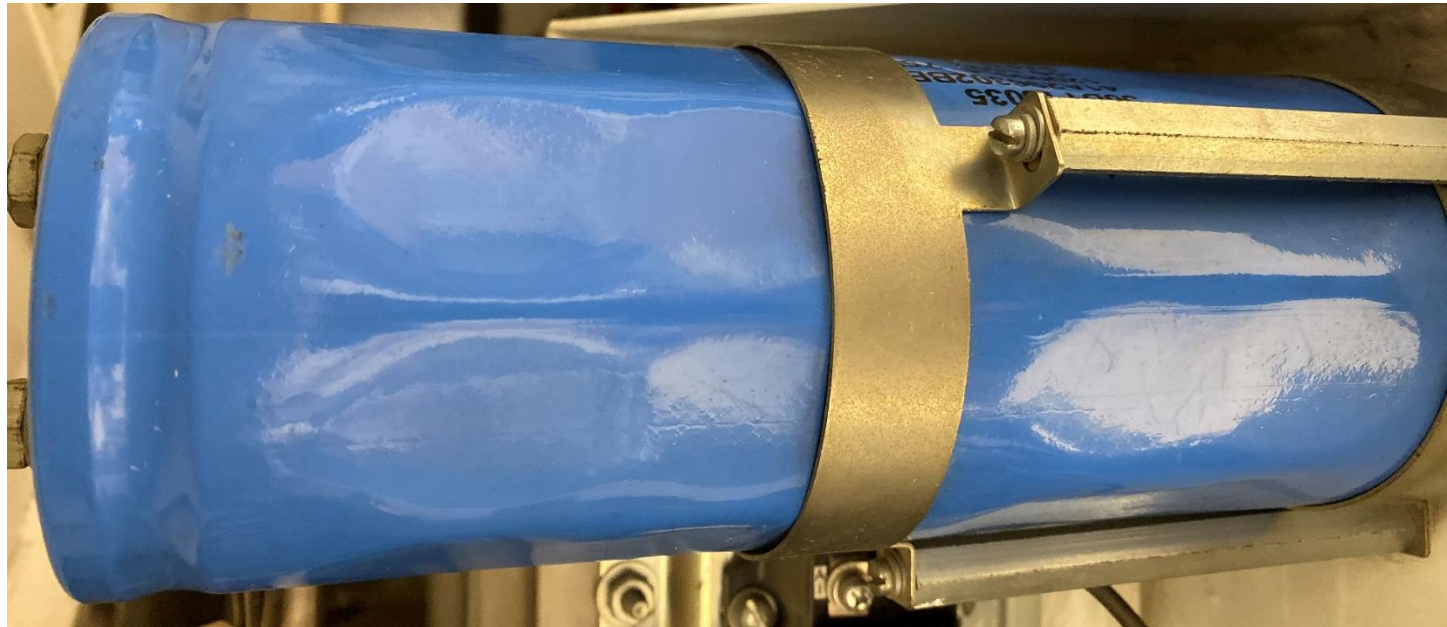

BATTERY HOLDUP CAPACITOR

41A296302BBP1

120,000UF @ 75 Volts



17FH41 Power Supply

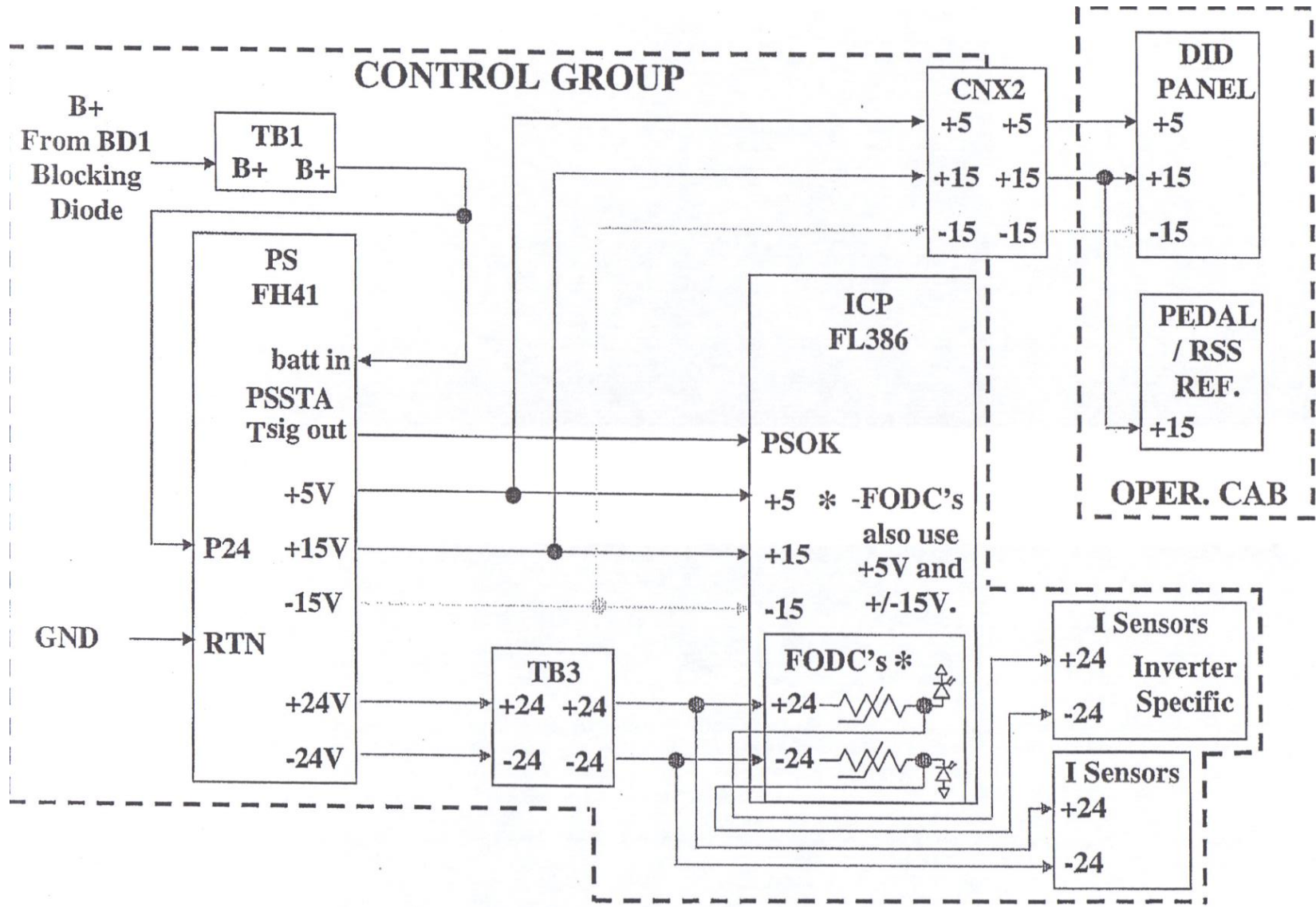

CONTROL POWER DISTRIBUTION

Figure 6

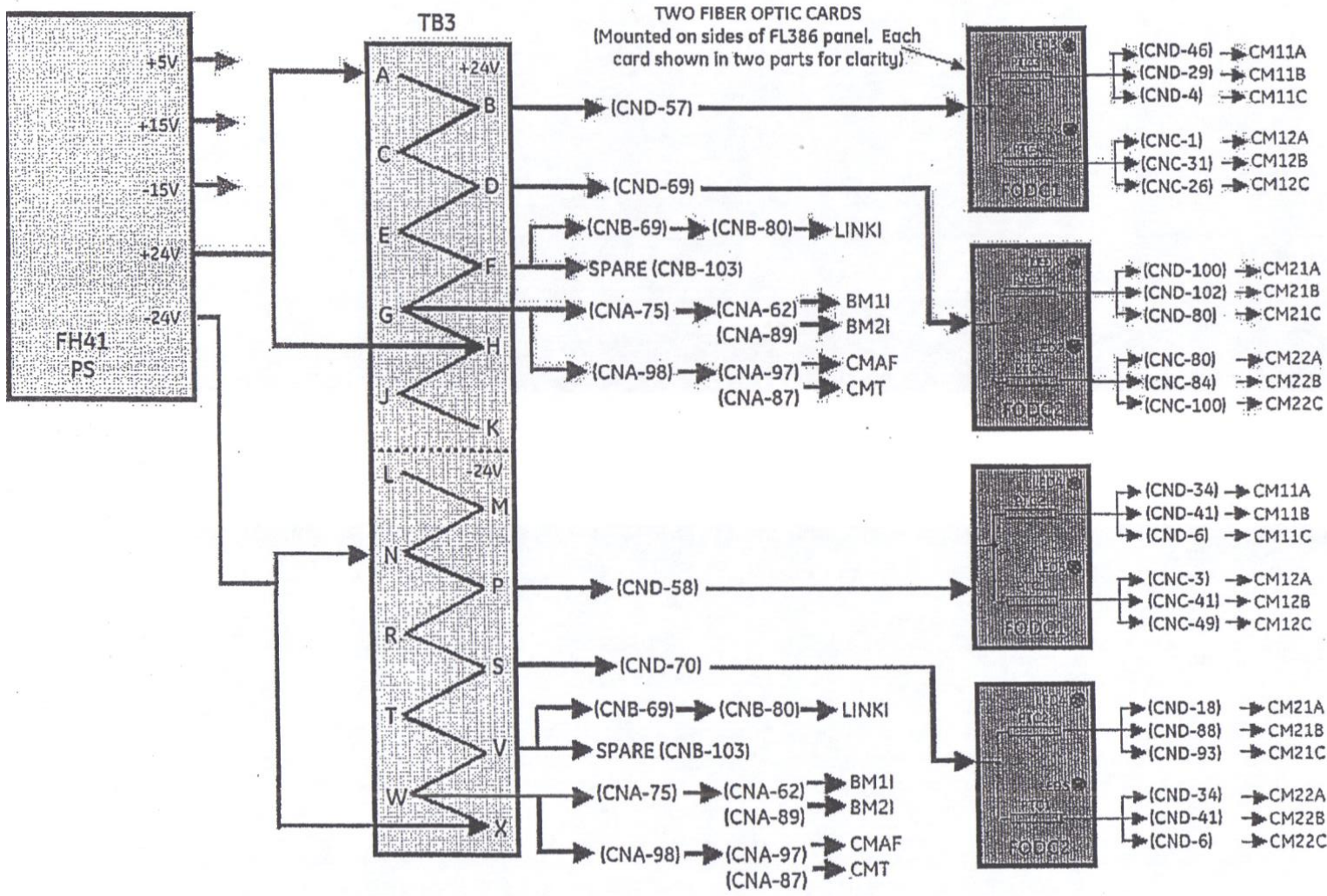

+ / - 24V POWER SUPPLY CONNECTIONS CURRENT SENSORS



41A296352CYP2 Gate Drive Power Converter

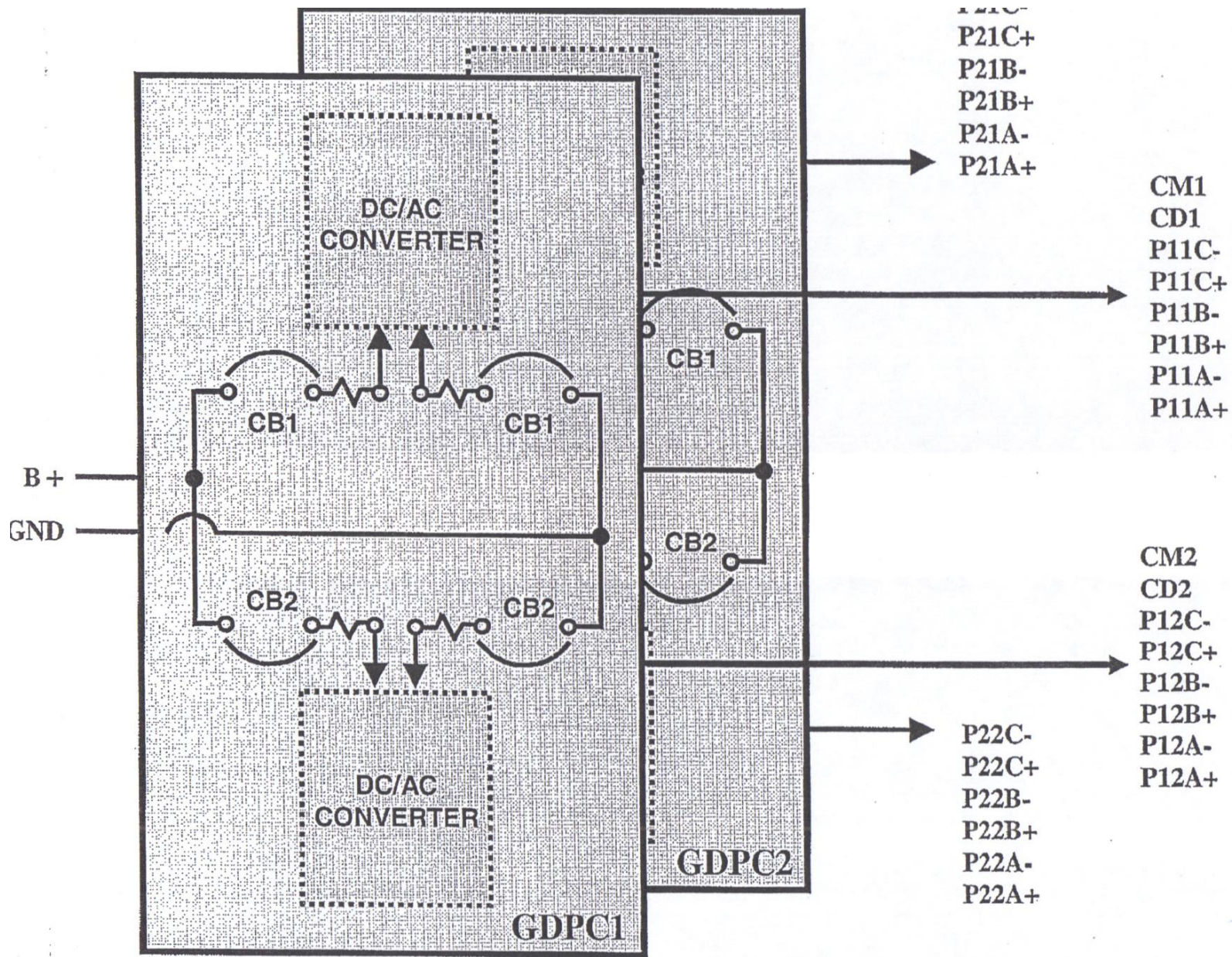

GATE DRIVE POWER CONVERTERS

Figure 65

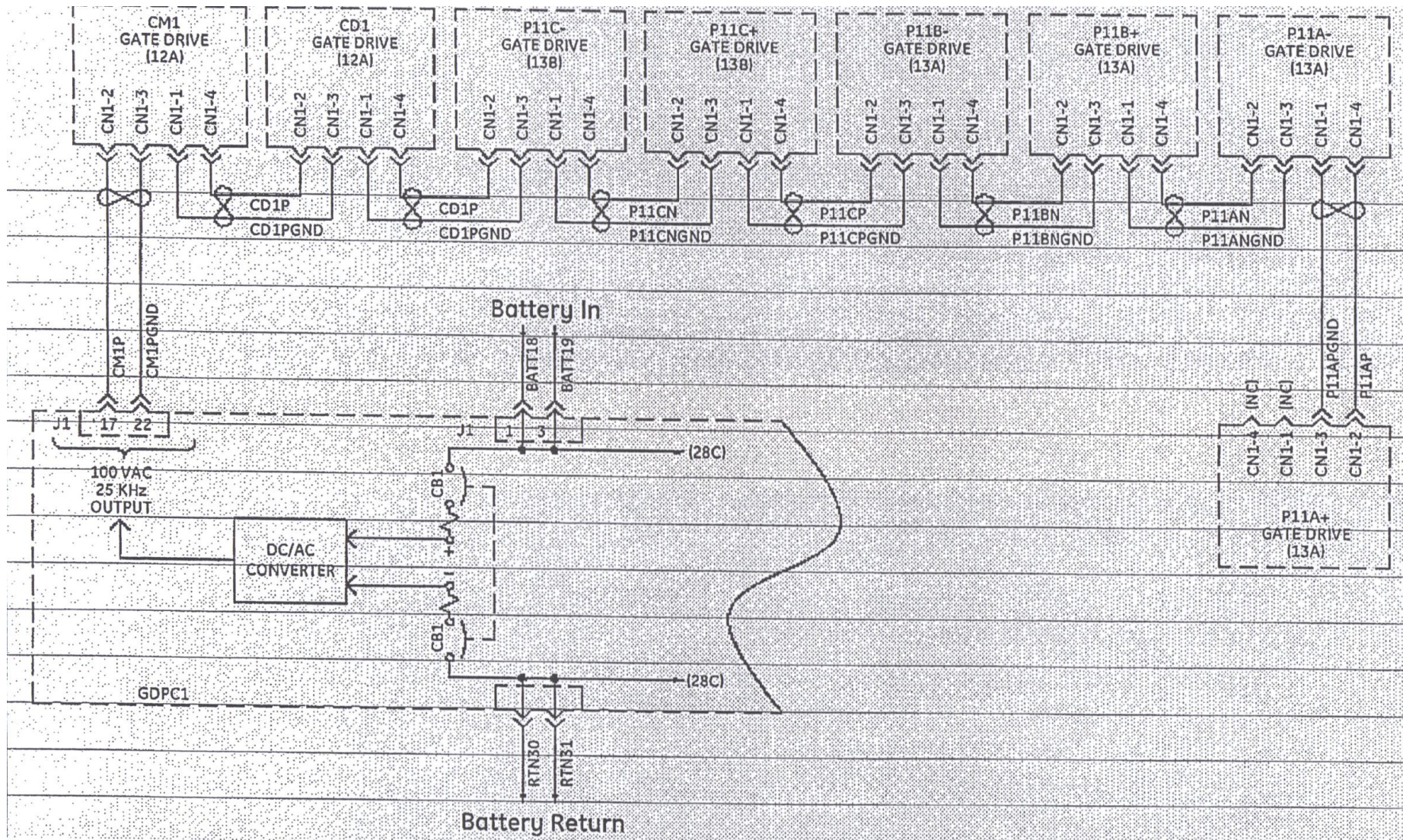

GATE DRIVE POWER SUPPLY

Figure 66

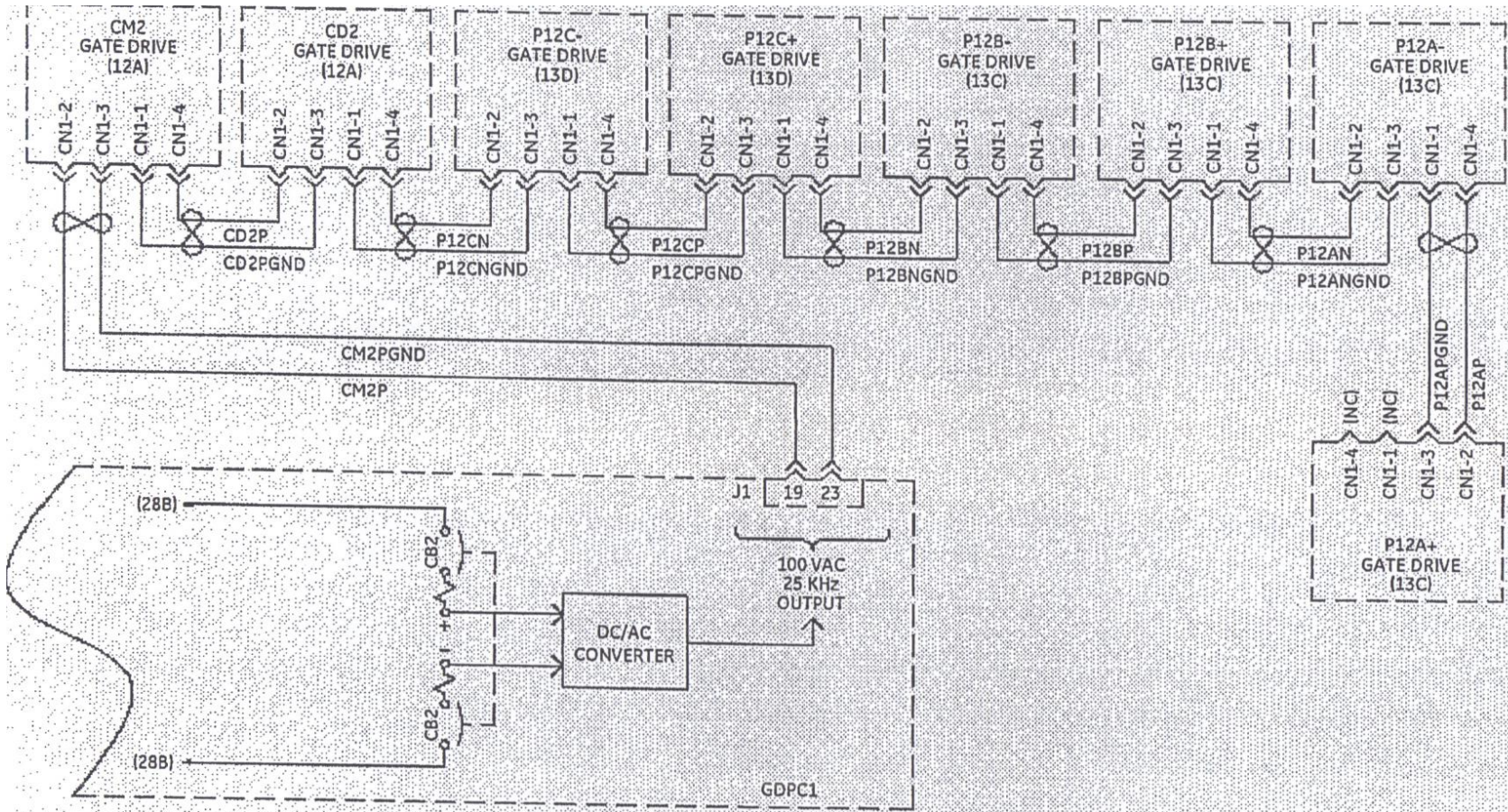

GATE DRIVE POWER SUPPLY

Figure 67



41A296328AKP2

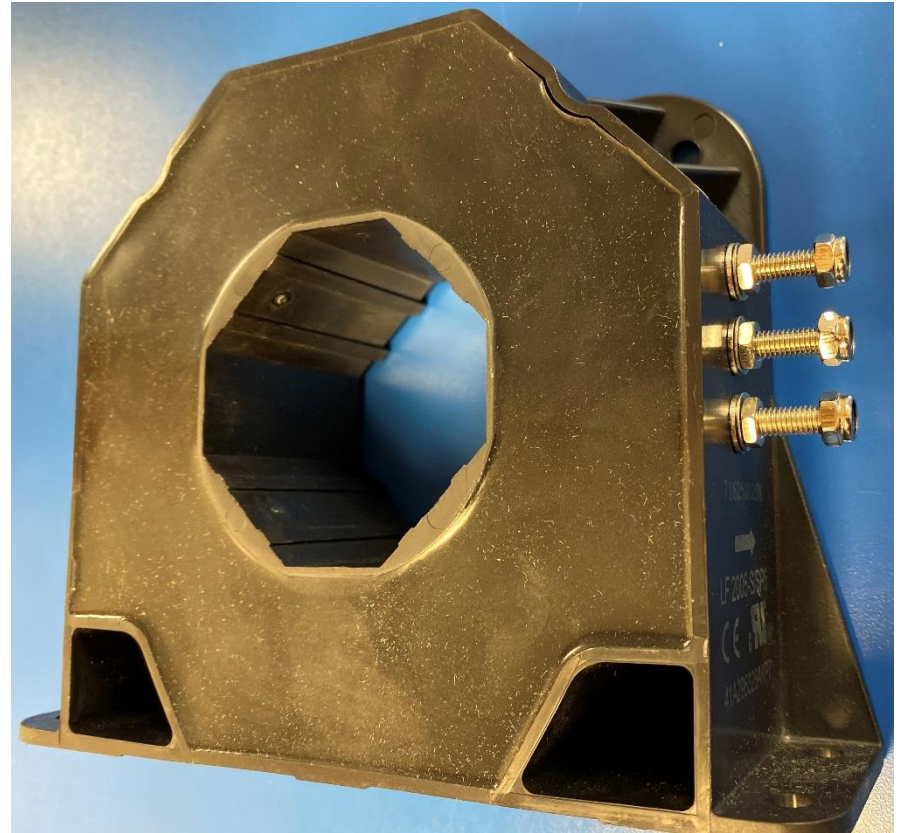

41A296327AKP7

CURRENT SENSOR

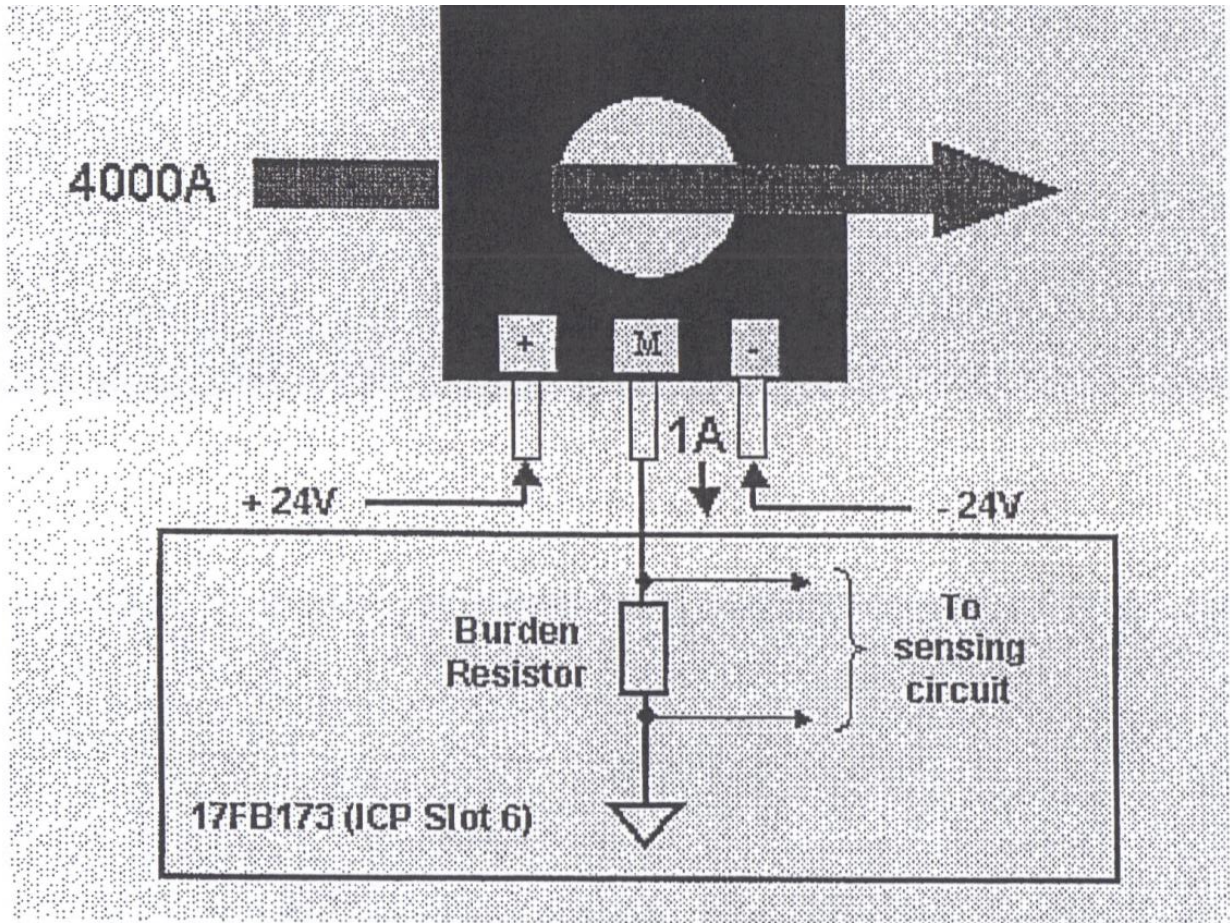

TYPICAL CURRENT SENSOR CONNECTIONS

<u>name</u>	<u>measures</u>	<u>Input Card</u>
CMAF	DC current in Alternator Field	FB173 (slot 6)
CMT	AC current in Alternator Tertiary	FB173 (slot 6)
BM1I	DC current in Grid Blower #1	FB173 (slot 6)
BM2I	DC current in Grid Blower #2	FB173 (slot 6)

P2 CURRENT SENSORS

Figure 70

<u>name</u>	<u>measures</u>	<u>Input Card</u>
CM11A	AC current in TA111 bus – INV11 phase A out.	FB179 (slot 11)
CM12A	AC current in TA112 bus – INV12 phase A out.	FB179 (slot 11)
CM11B	AC current in TB111 bus – INV11 phase B out.	FB179 (slot 11)
CM12B	AC current in TB112 bus – INV12 phase B out.	FB179 (slot 11)
CM11C	AC current in TC111 bus – INV11 phase C out.	FB179 (slot 11)
CM12C	AC current in TC112 bus – INV12 phase C out.	FB179 (slot 11)
CM21A	AC current in TA221 bus – INV21 phase A out.	FB179 (slot 12)
CM22A	AC current in TA222 bus – INV22 phase A out.	FB179 (slot 12)
CM21B	AC current in TB221 bus – INV21 phase B out.	FB179 (slot 12)
CM22B	AC current in TB222 bus – INV22 phase B out.	FB179 (slot 12)
CM21C	AC current in TC221 bus – INV21 phase C out.	FB179 (slot 12)
CM22C	AC current in TC222 bus – INV22 phase C out.	FB179 (slot 12)
LINKI	DC current in DCN bus – near connection to negative rectifier bus	FB173 (slot 6)

P7 CURRENT SENSORS

Figure 71



*17FM702 VOLTAGE
ATTENUATION MODULE*



*17FM681 VOLTAGE
ATTENUATION MODULE*

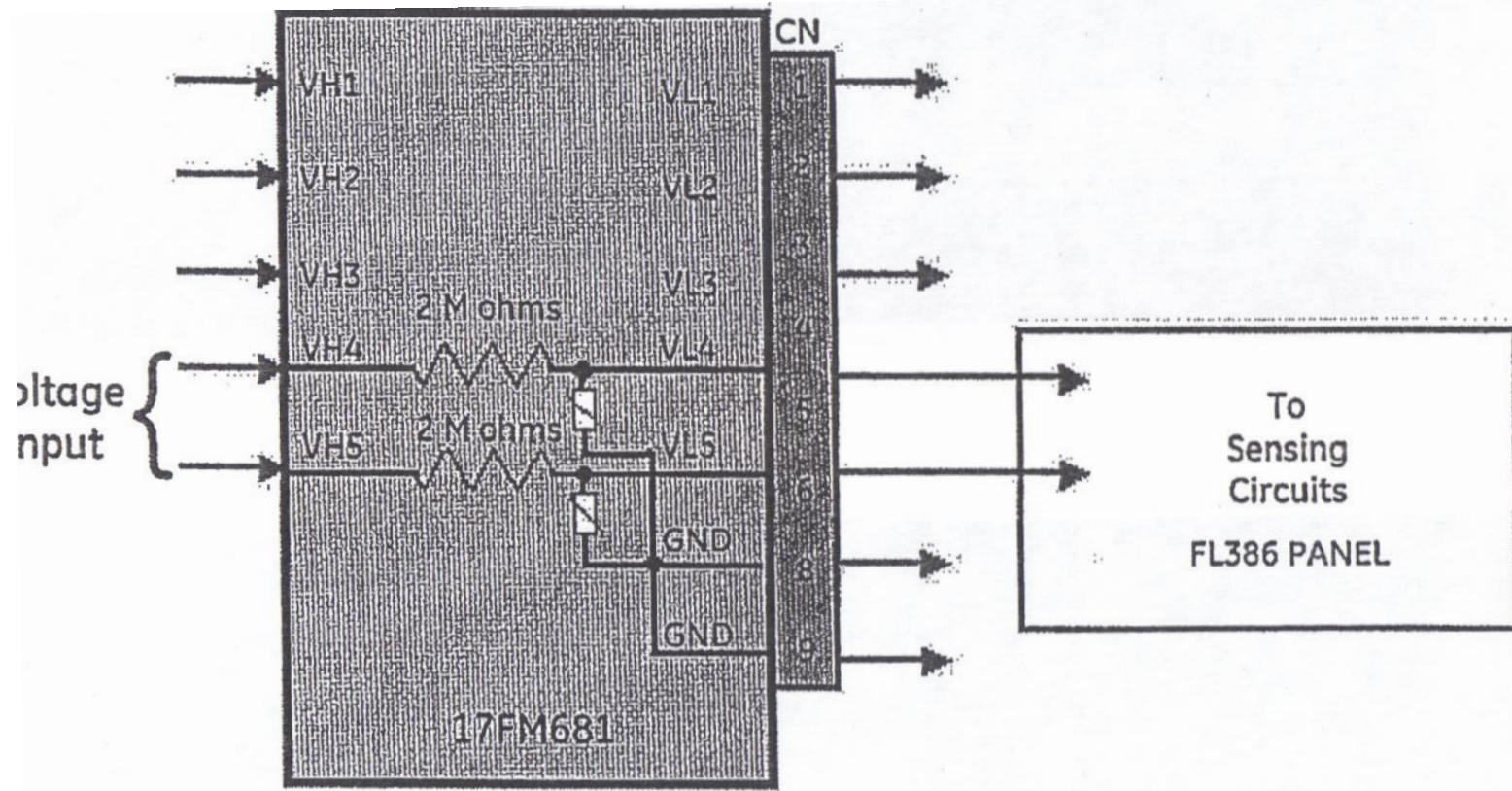

VAM's (VOLTAGE ATTENUATION MODULES)

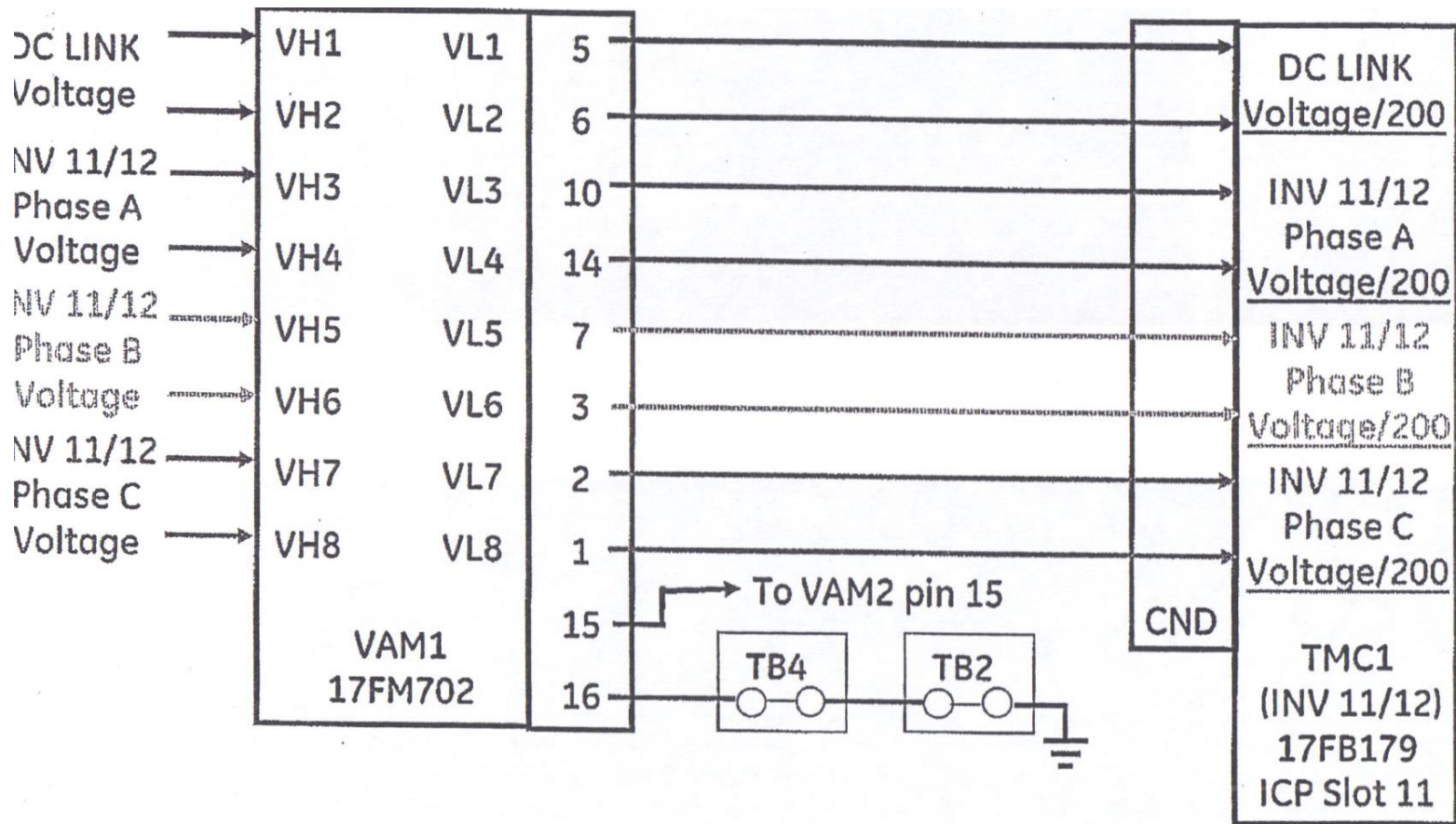

VAM1 – INV11/12 VOLTAGE FEEDBACKS

Figure 74

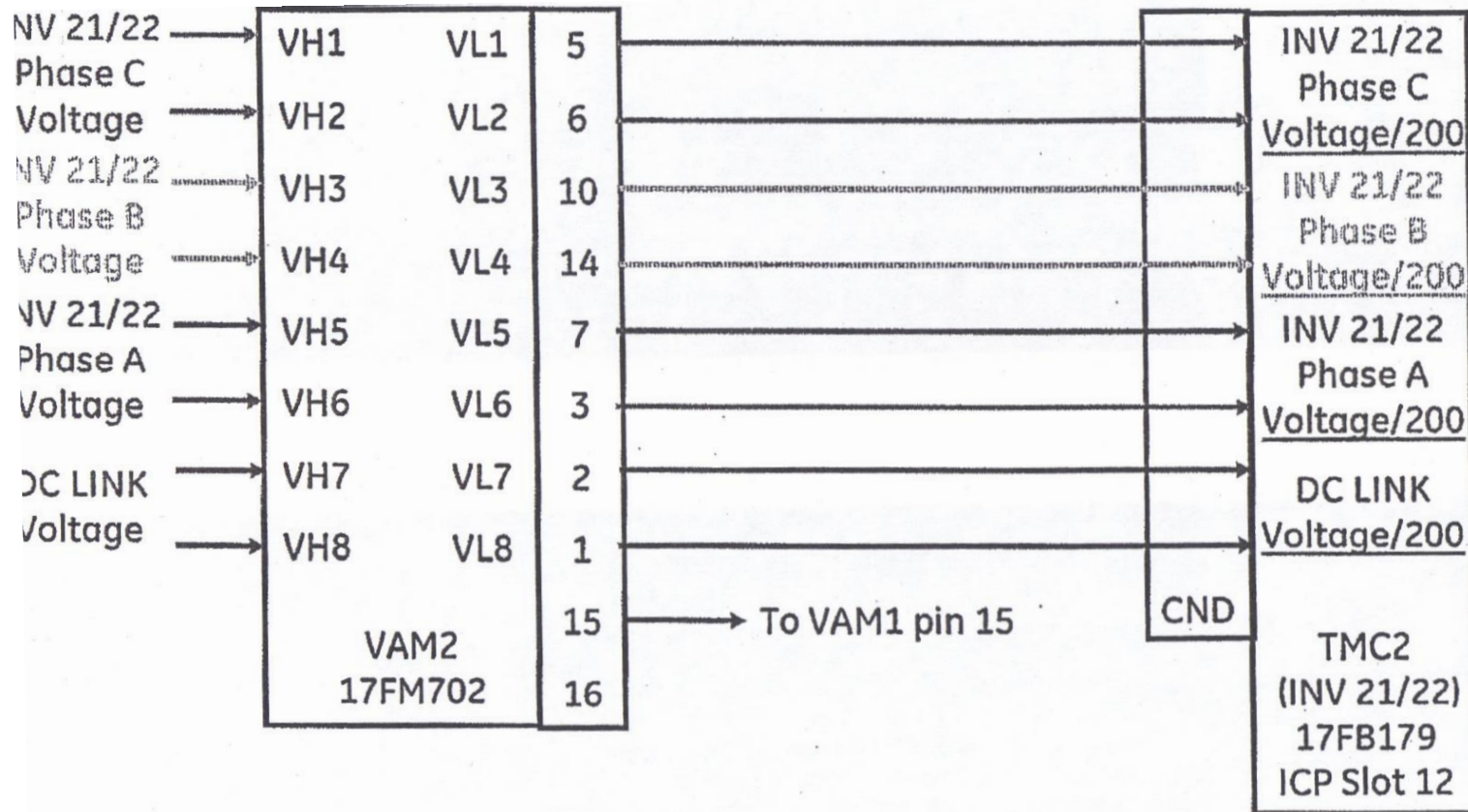

VAM2-INV21/22 VOLTAGE FEEDBACKS

Figure 75

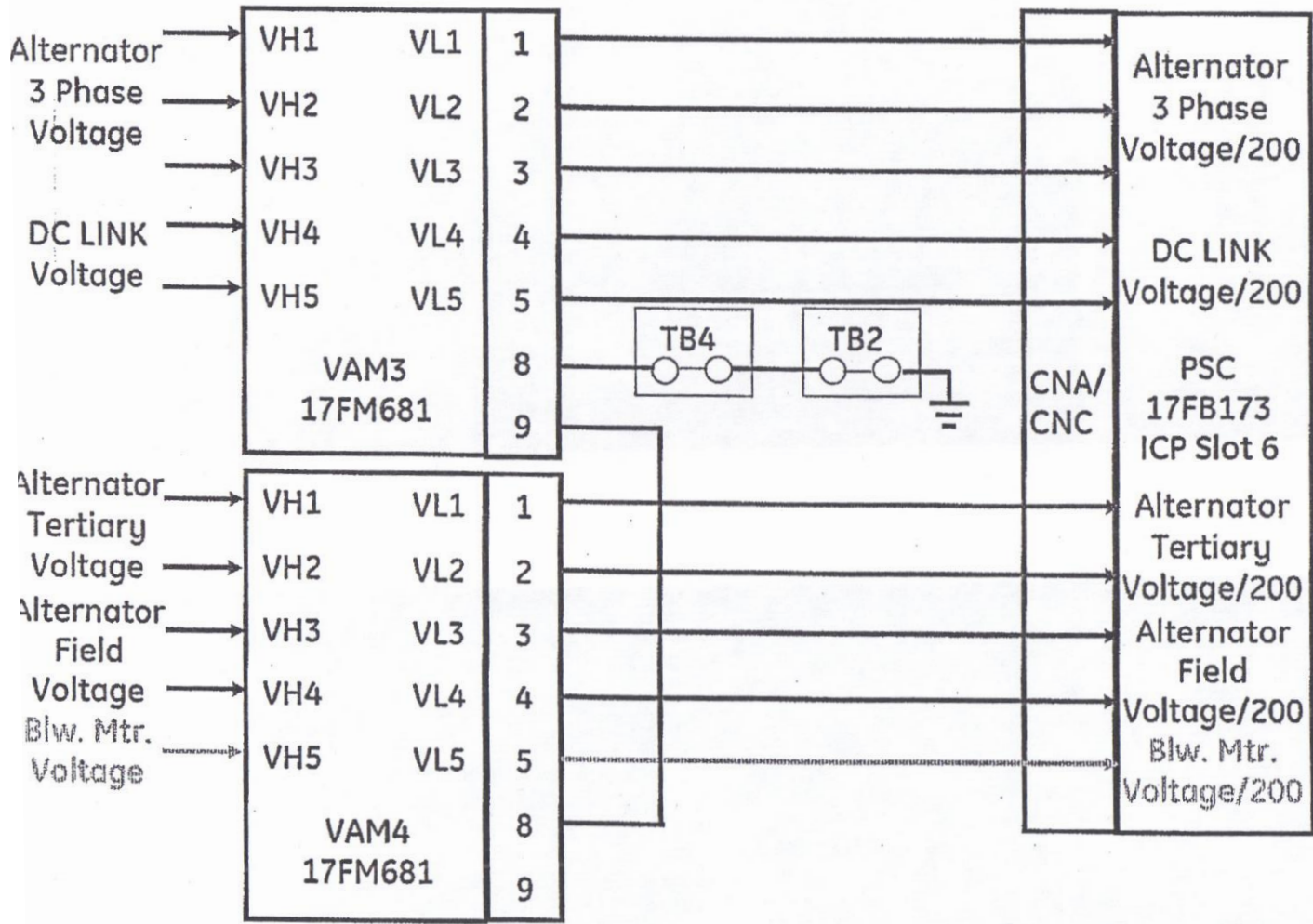

VAM3/4 – SYSTEM VOLTAGE FEEDBACKS

Figure 76

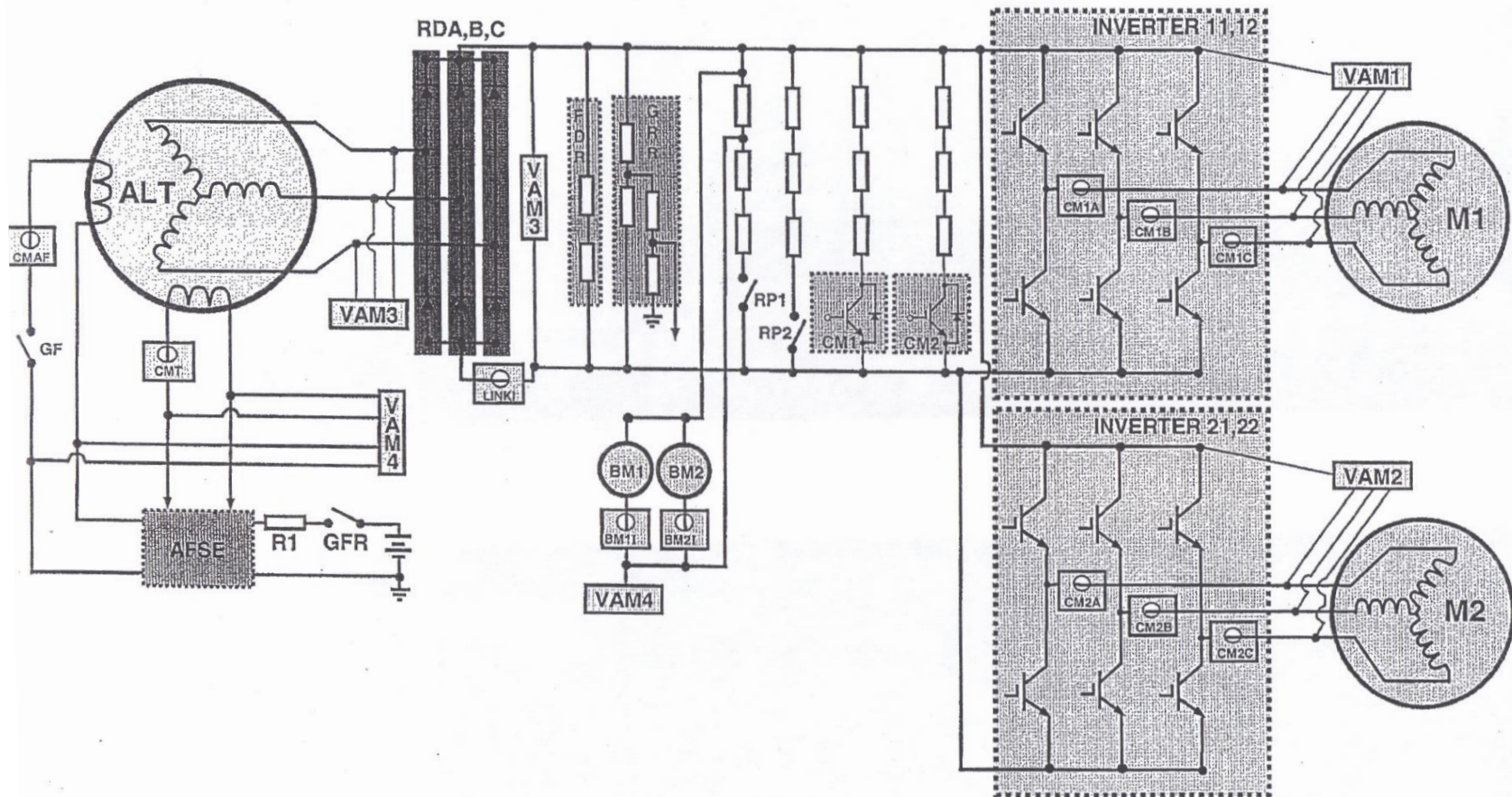

FEEDBACKS OVERVIEW

Figure 77

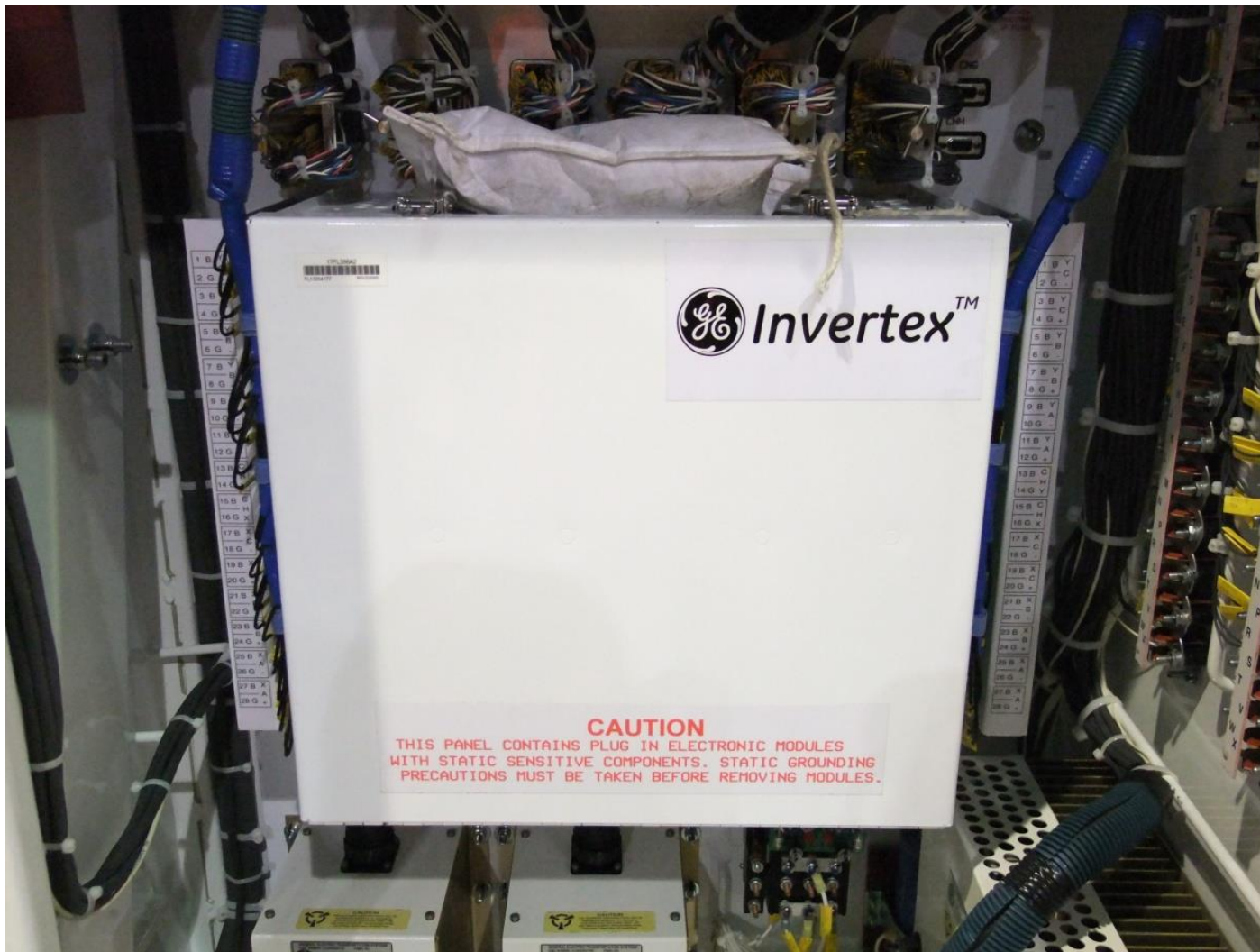

17FL386 Integrated Control Panel (DUAL IGBT)



17FL386 Integrated Control Panel (DUAL IGBT)

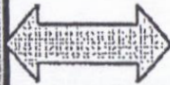
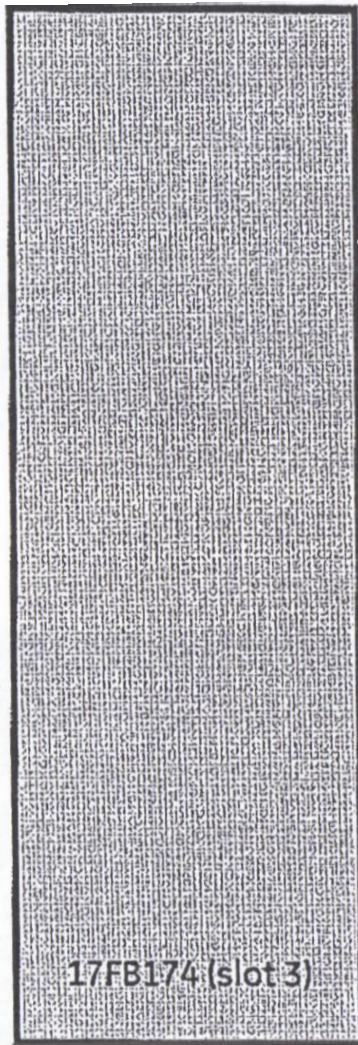

PSC DIG. I/O 17FB104 Card (slot 5)

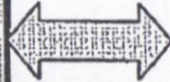

PSC AN. I/O 17FB173 Card (slot 6)

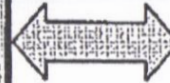

TCI CPU 17FB174 Card (slot 7)

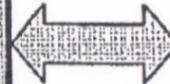

INV 11/12 TMC1 17FB179 Card (slot 11)



INV 21/22 TMC2 17FB179 Card (slot 12)

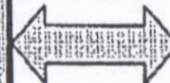

PTU COMPUTER (serial port back of center console)

FB174 PSC CPU BOARD

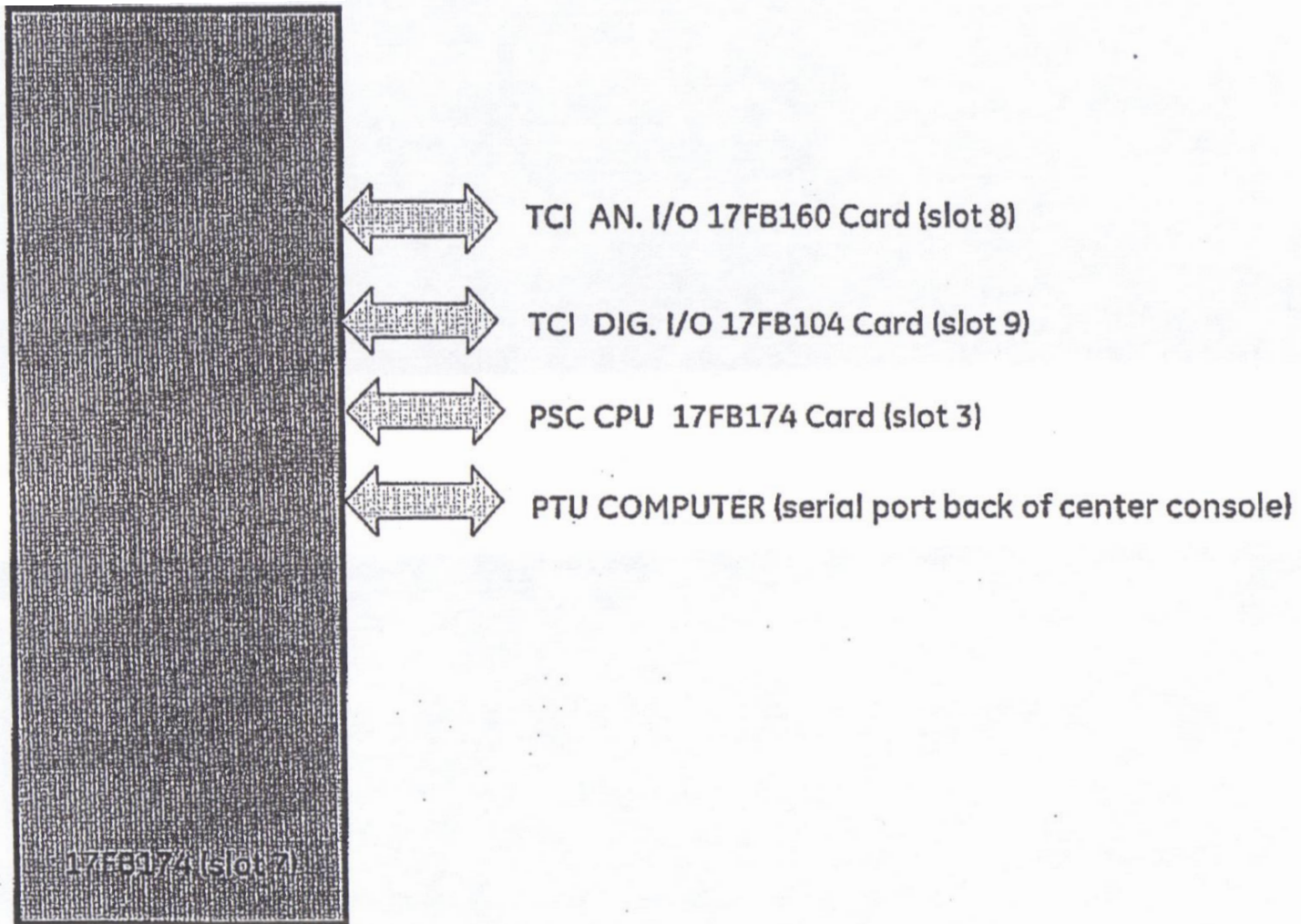

17FB174 TCI CPU BOARD

Figure 83

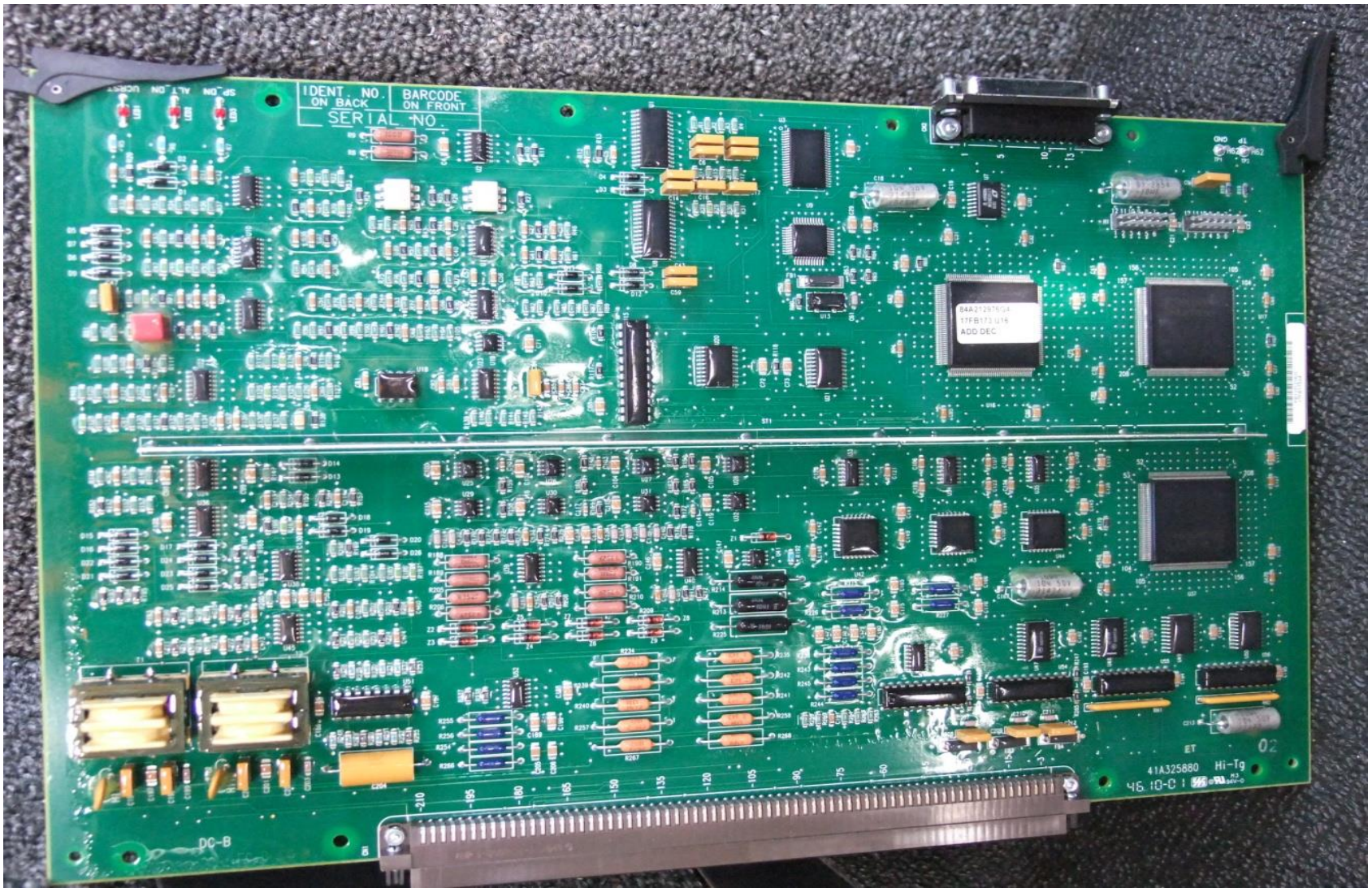

17FB173 PSC Analog Card

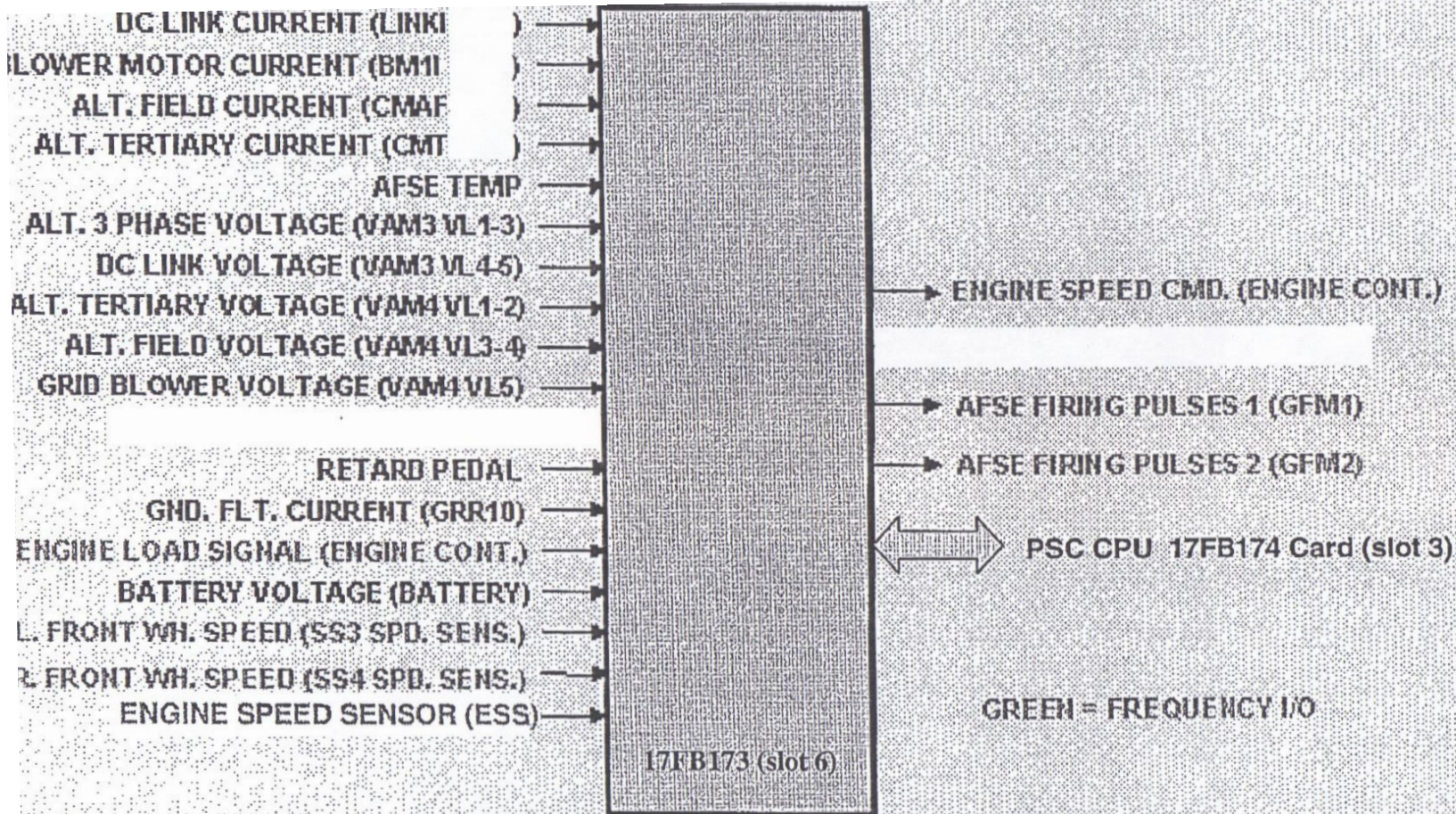

FB173 PSC ANALOG I/O BOARD



17FB160 TCI Analog Card

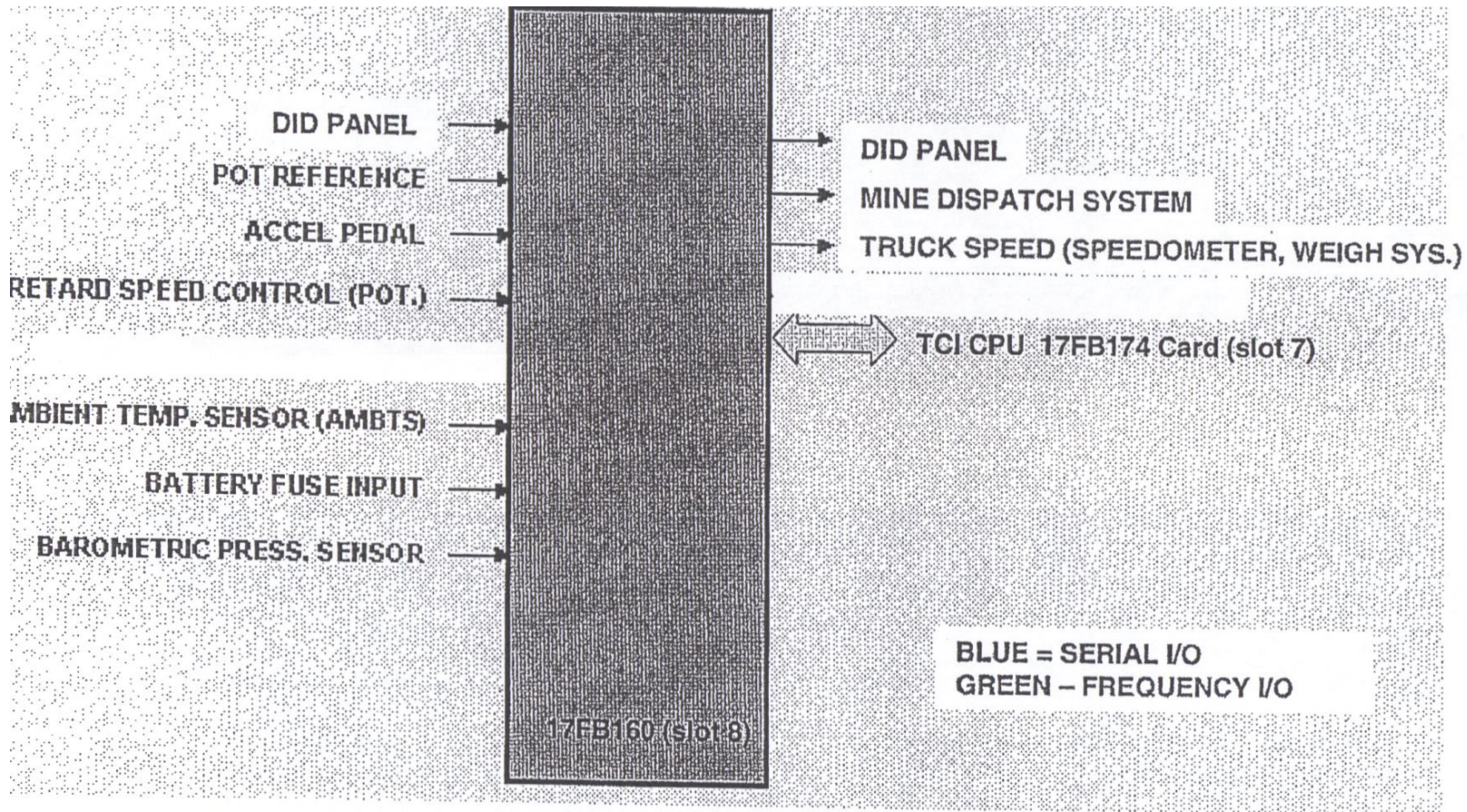

FB160 TCI ANALOG I/O BOARD

Figure 84

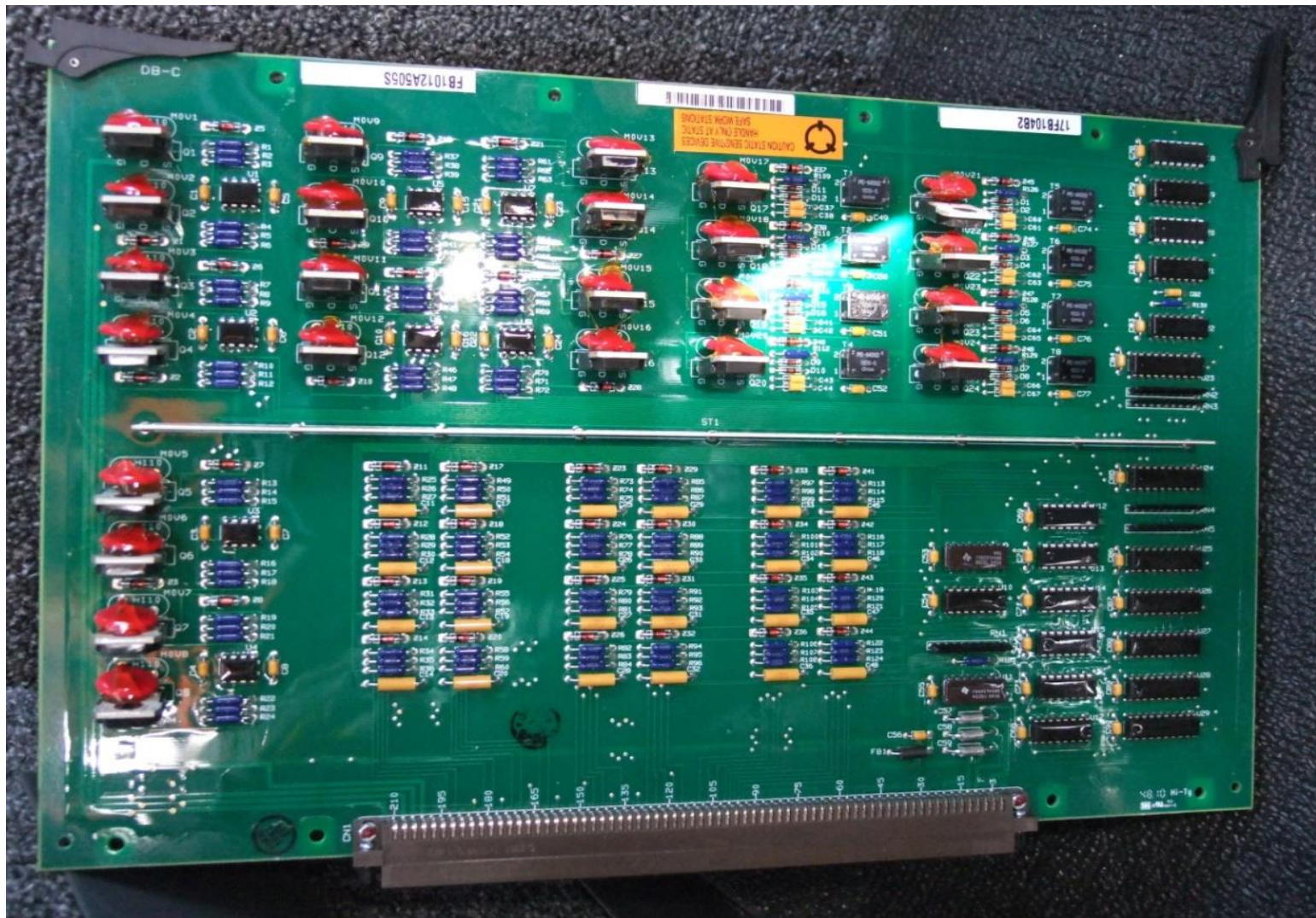

17FB104 Digital I/O Card

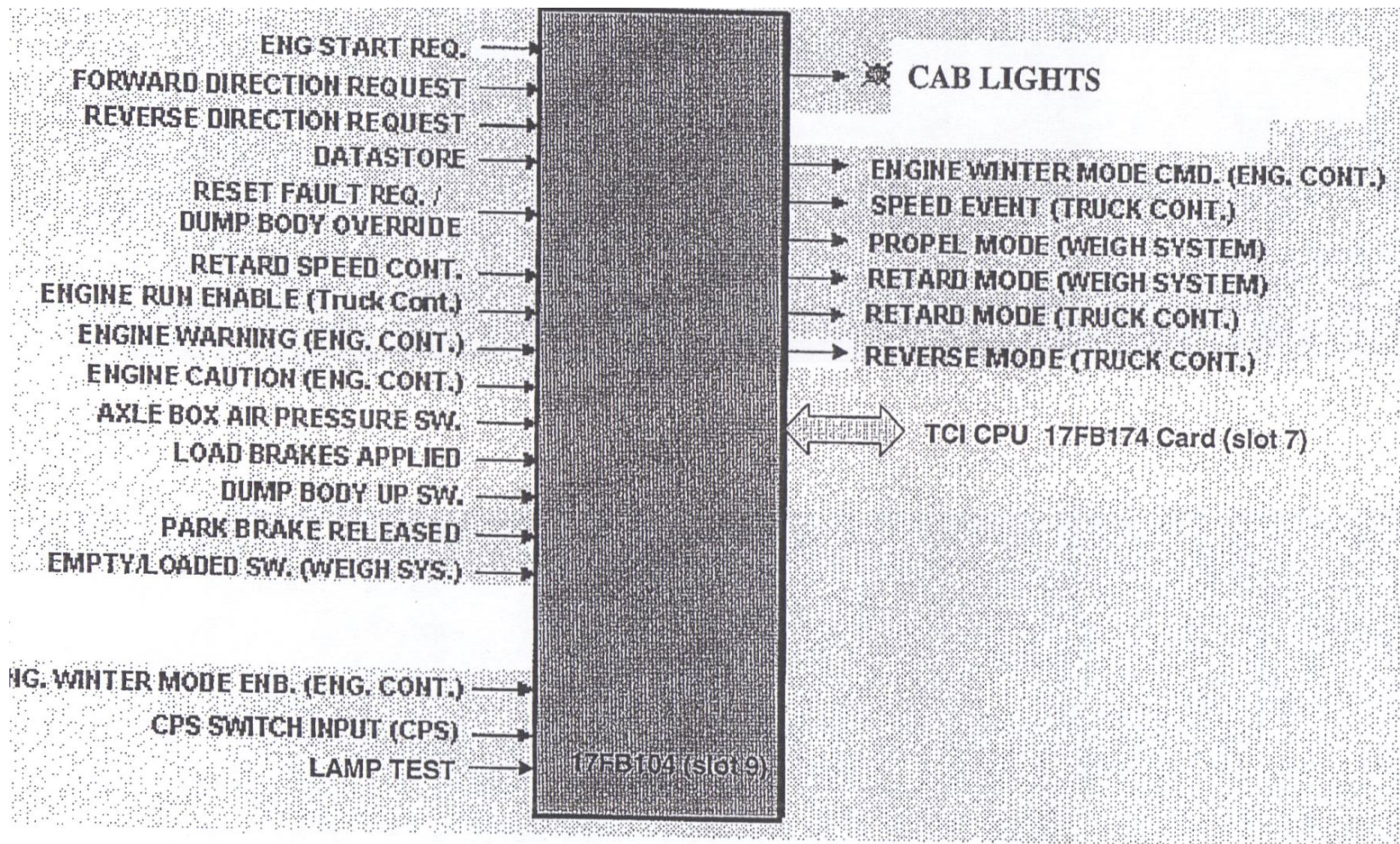

FB104 TCI DIGITAL I/O BOARD

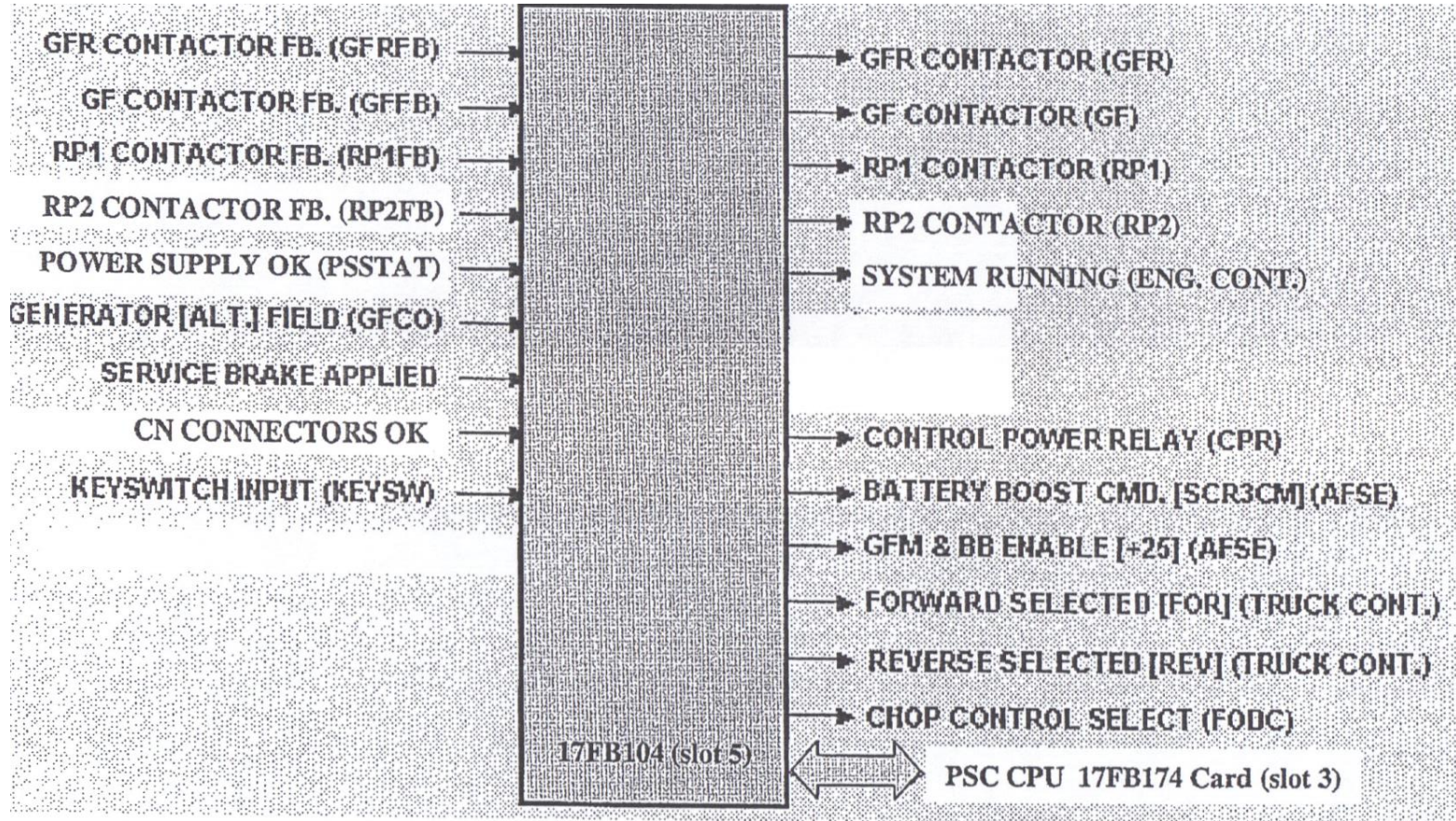

FB104 PSC DIGITAL I/O BOARD

Figure 81

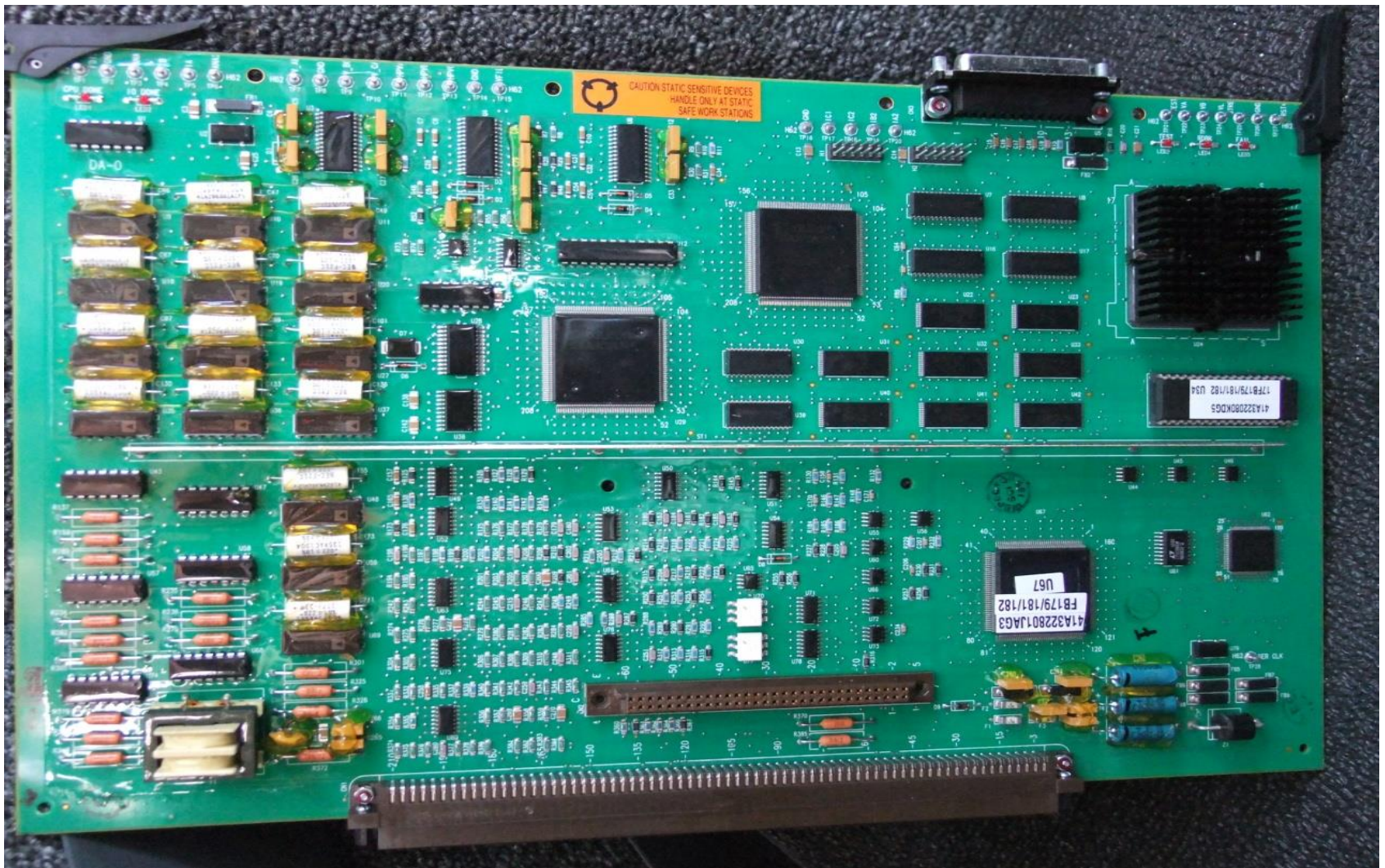

17FB179 Inverter Control Card

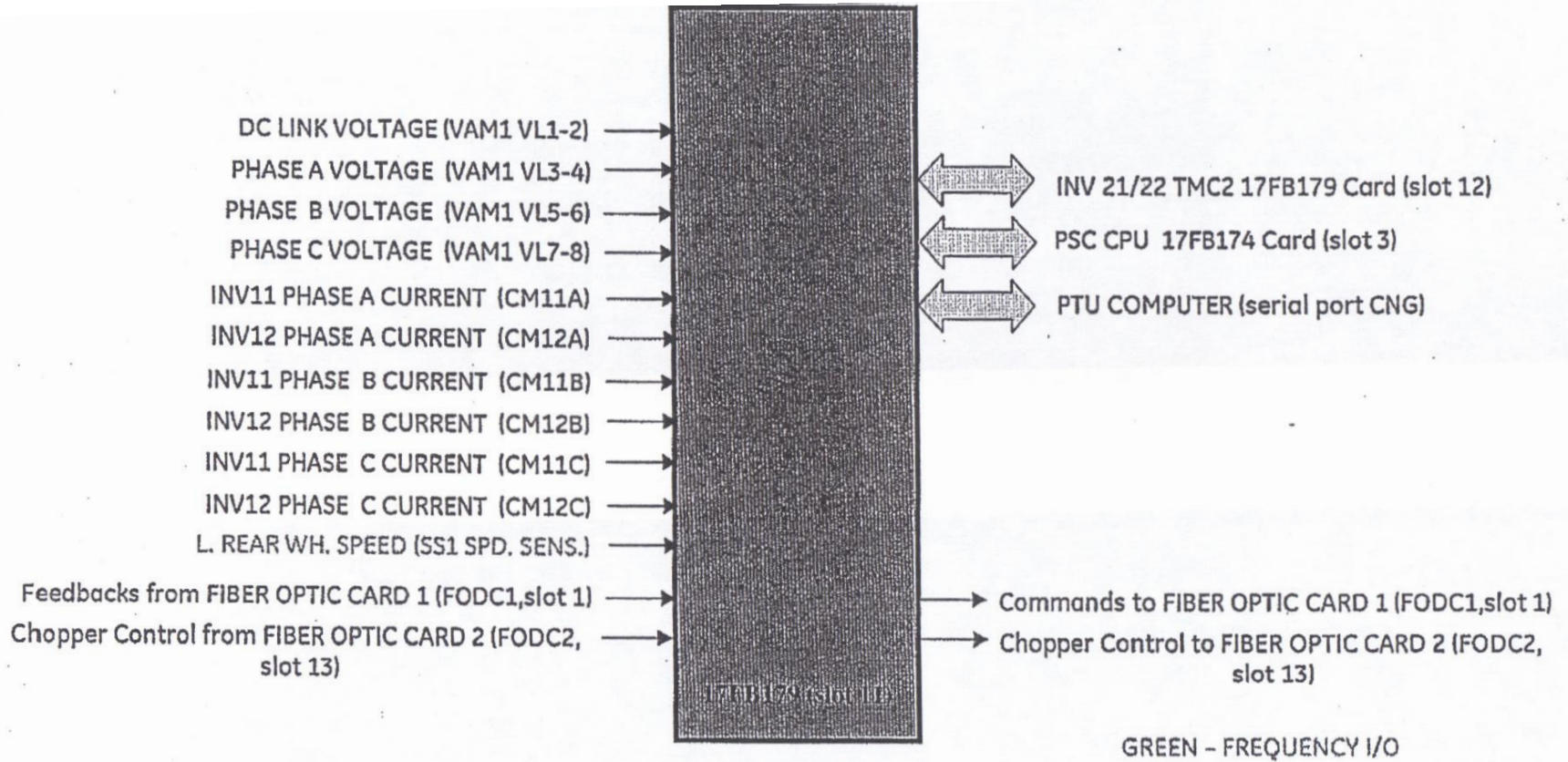

17FB179 TMC INVERTER 1 BOARD (TRACTION MOTOR CONTROL)

Figure 80

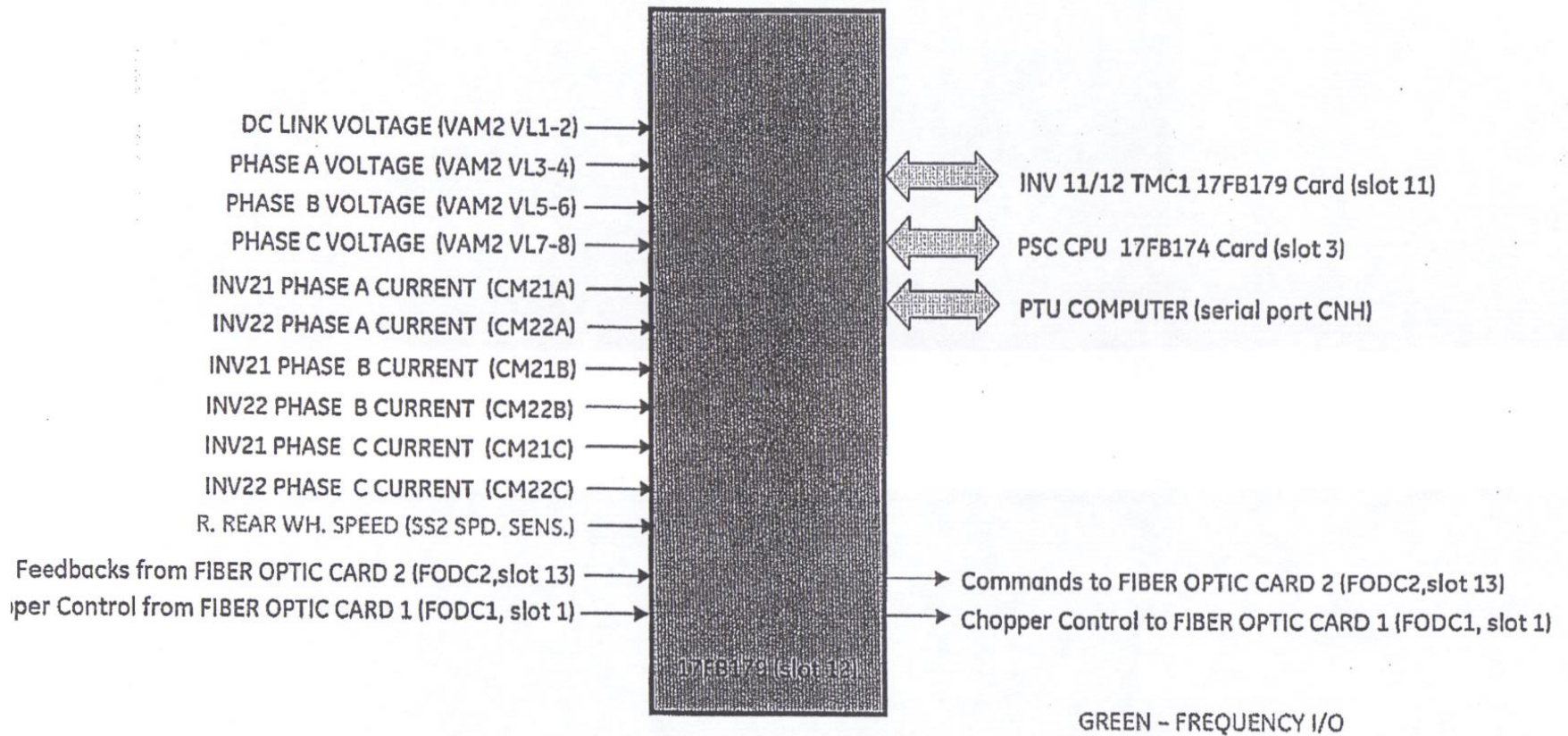

FB179 TMC INVERTER 2 BOARD (TRACTION MOTOR CONTROL)

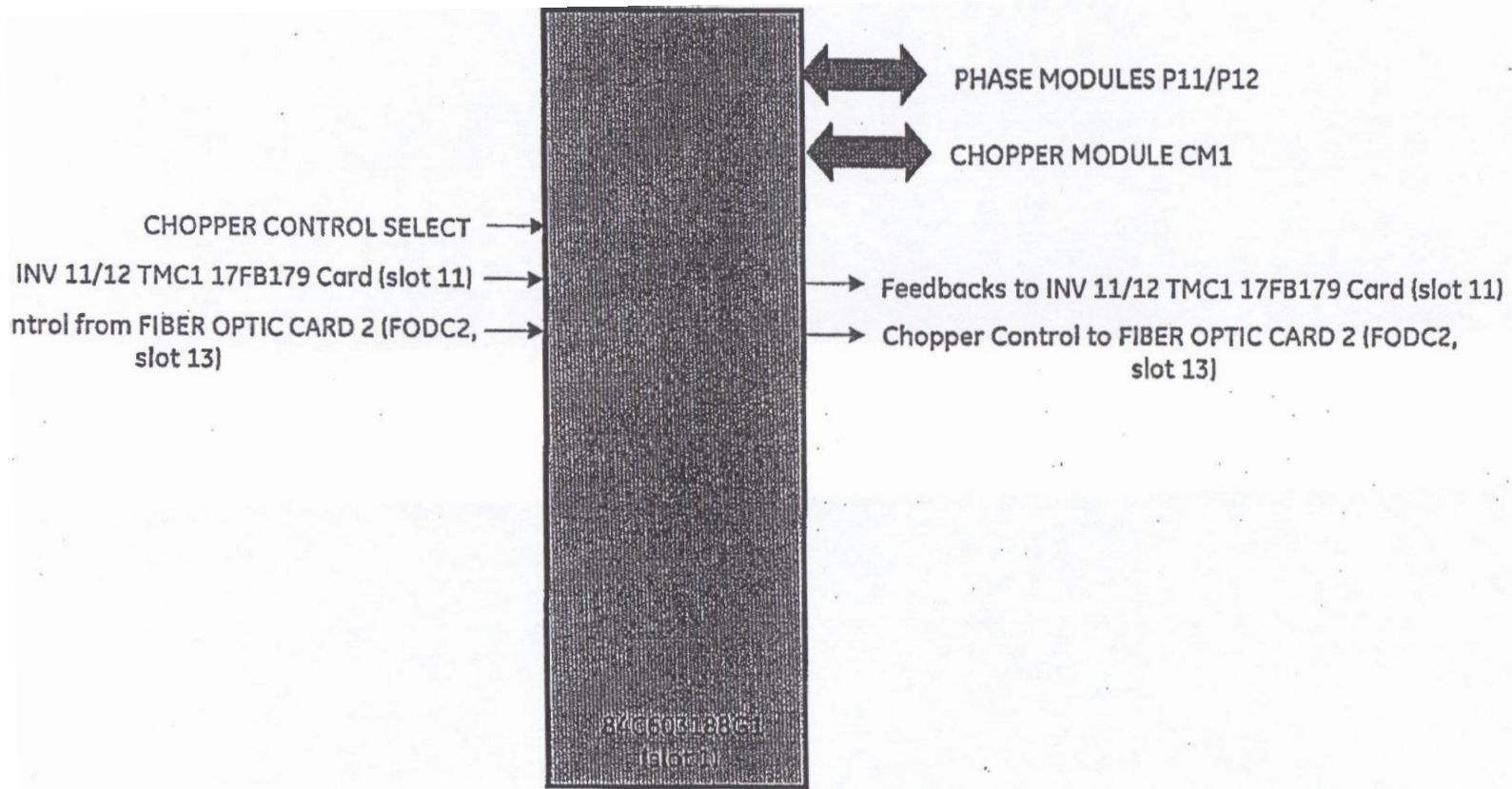

FIBER OPTIC BOARD 1 (FODC1)

Figure 87

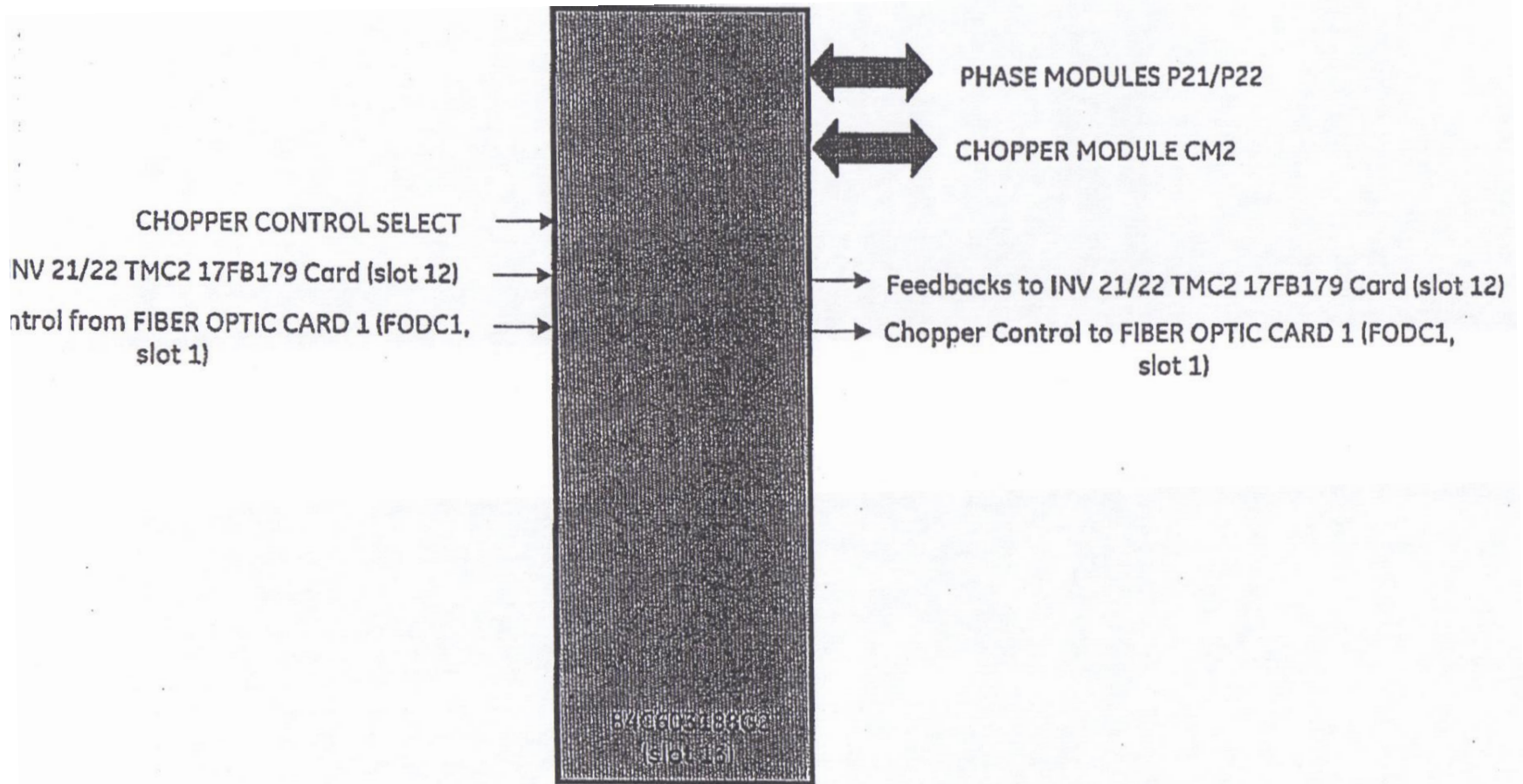

FIBER OPTIC BOARD 2 (FODC2)

Invertex 2 Card Rack

Part Number 17FL453B1



84B527044AD
ISSUE 05 04

DRIVE SYSTEM CONTROL PANEL

SECT. 84A

SECT. 84B

DRIVE SYSTEM CONTROL PANEL

THIS DRAWING, WHICH CONTAINS PROPRIETARY INFORMATION, IS THE PROPERTY OF GENERAL ELECTRIC COMPANY. IT SHALL NOT BE REPRODUCED IN ANY MANNER NOR DISCLOSED TO THIRD PARTIES WITHOUT WRITTEN PERMISSION OF GENERAL ELECTRIC COMPANY.

17FL453 DRIVE SYSTEM CONTROL PANEL (DSC)

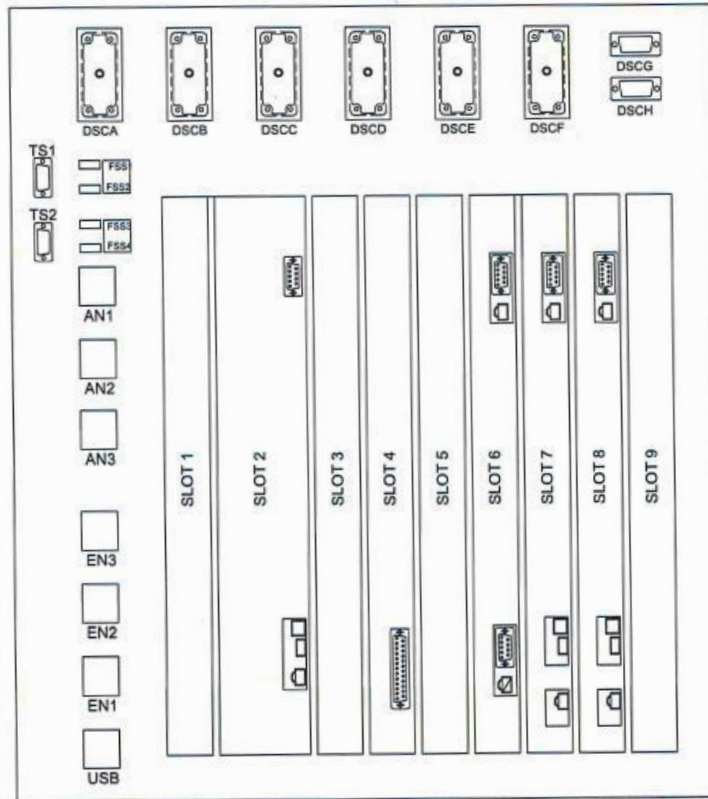

(FRONT VIEW)

SLOT	DESCRIPTION	FACE PLATE CONNECTORS
1	INVERTER #1 FIBER OPTIC FODC1 (84C603188)	
2	SYSTEM CPU (17FB187)	(1) DB9, (1) RJ45, USB MASTER, USB SLAVE
3	DIGITAL I/O (17FB104) CARD #1	NONE
4	ANALOG (17FB173)	(1) DB25
5	DIGITAL I/O (17FB104) CARD #2	NONE
6	ETHERNET SWITCH CARD (17FB191)	(2) DB9, (2) RJ45
7	INVERTER #1 TMC (17FB190)	(1) DB9 (17FB190)
8	INVERTER #2 TMC (17FB190)	(1) DB9 (17FB190)
9	INVERTER #2 FIBER OPTIC FODC2 (84C603188)	

TITLE	SYSTEM SCHEMATIC
FIRST MADE FOR	GE240AC

MADE BY	R. LUDWIGSON	5.11.12
ISSUE	R. LUDWIGSON	5.11.12

APPROVAL
 & PUBLICOVER

CONTROL
 GENERAL ELECTRIC CO.

ERIC
 FLAY

84B527044AD
ISSUE 05 04

84B527044AD

CONT. ON BDL 10 REV. 9

BLOCK DIAGRAM: DRIVE SYSTEM CONTROL

SECT. 9A

SECT. 9B

BLOCK DIAGRAM: DRIVE SYSTEM CONTROL

THIS DRAWING, WHICH CONTAINS PROPRIETARY INFORMATION, IS THE PROPERTY OF GENERAL ELECTRIC COMPANY. IT SHALL NOT BE REPRODUCED IN ANY MANNER NOR DISCLOSED TO THIRD PARTIES WITHOUT WRITTEN PERMISSION OF GENERAL ELECTRIC COMPANY.

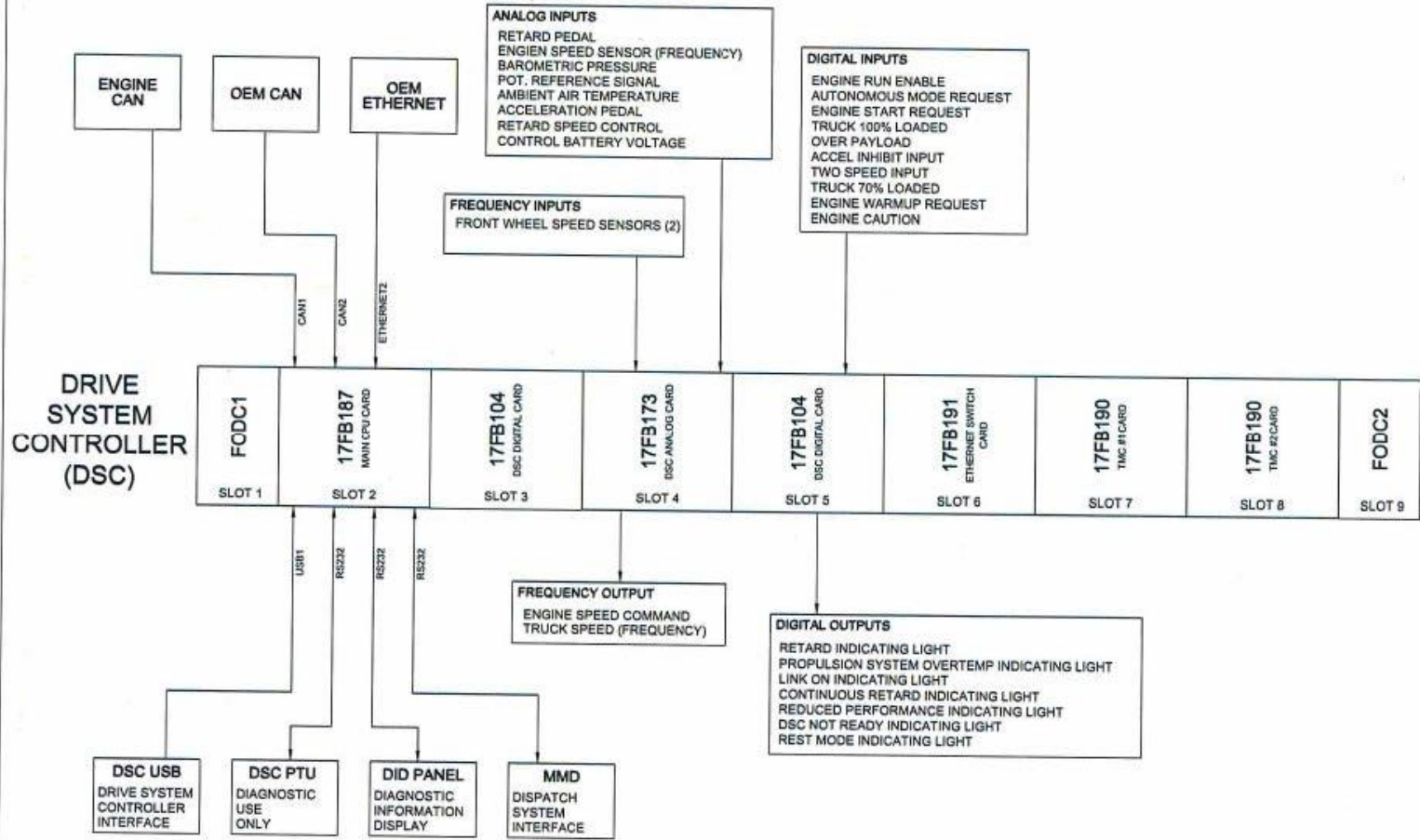

REV	TITLE	DATE
	SYSTEM SCHEMATIC	
	FIRST MADE FOR	GE240AC

MADE BY	R. LUDWIGSON	5.11.12
ISSUE	R. LUDWIGSON	5.11.12

APPROVAL	CONTROL
D. PUBLICOVER	GENERAL ELECTRIC CO

ERIC FLANT	84B527044AD
	CONT. ON BDL 10 REV. 9

Ambient Temperature Sensor

Part Number 41C668507G1

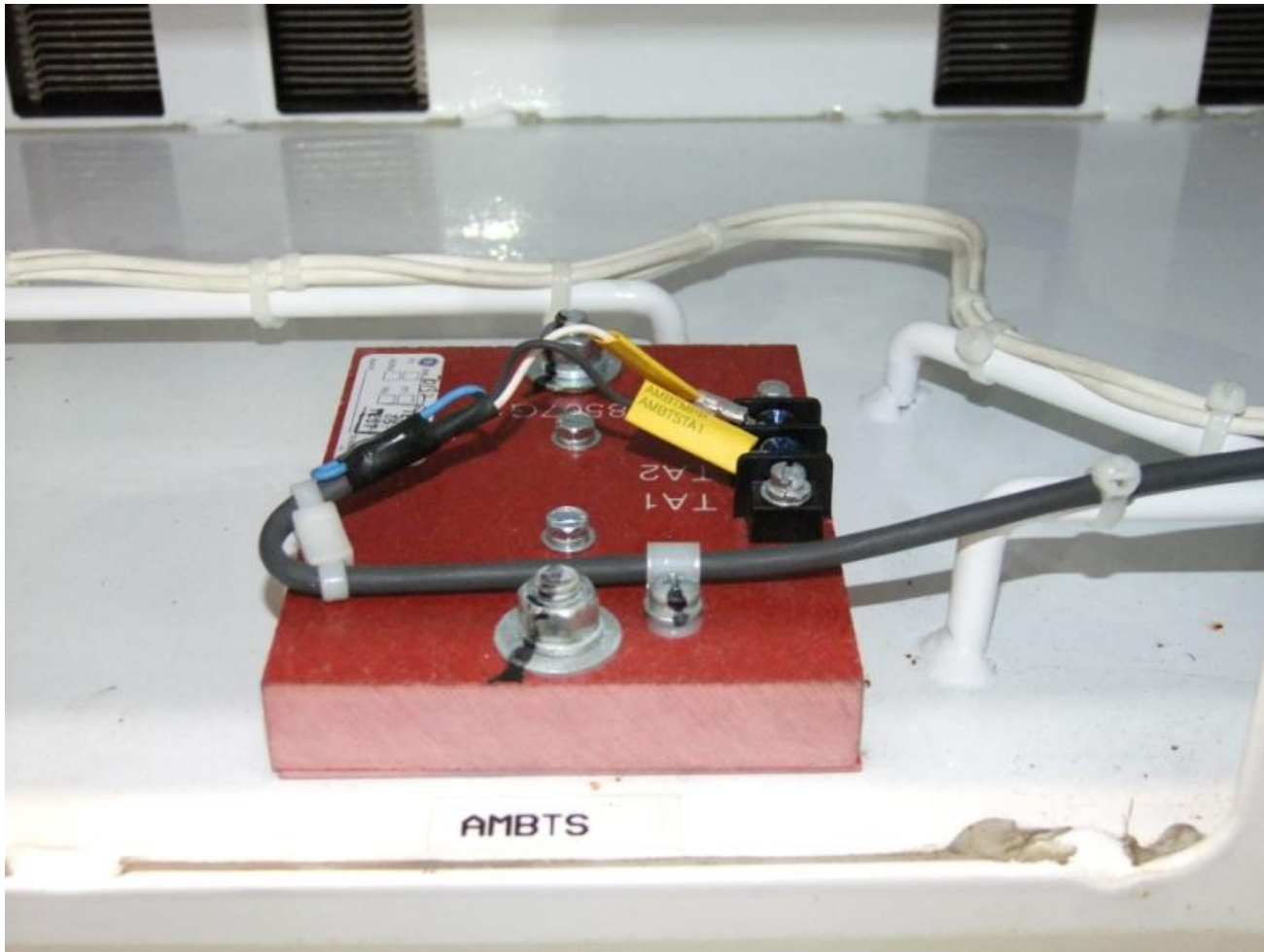

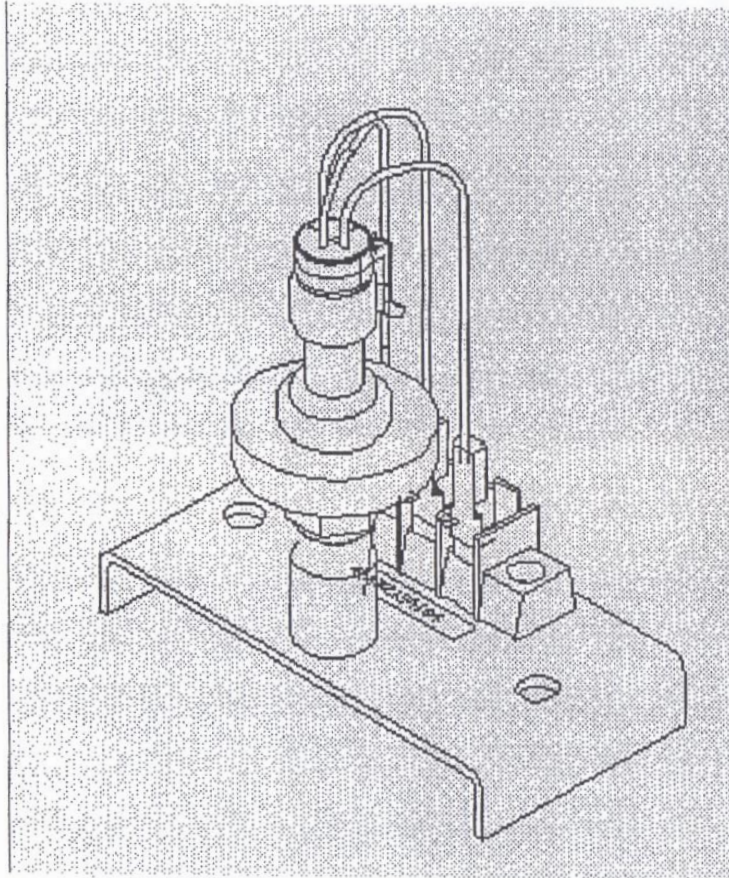
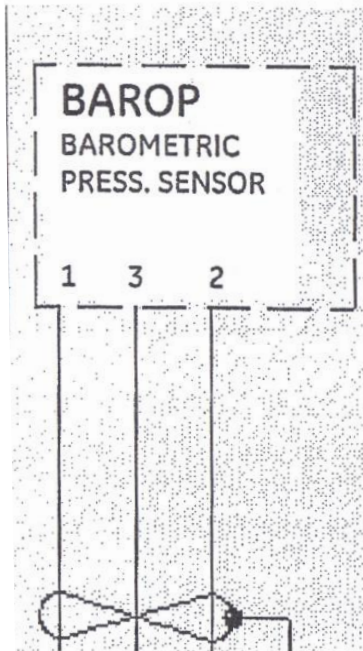

BAROMETRIC PRESSURE SENSOR

Capacitor Charge Light Resistor Panel 41C666558G1

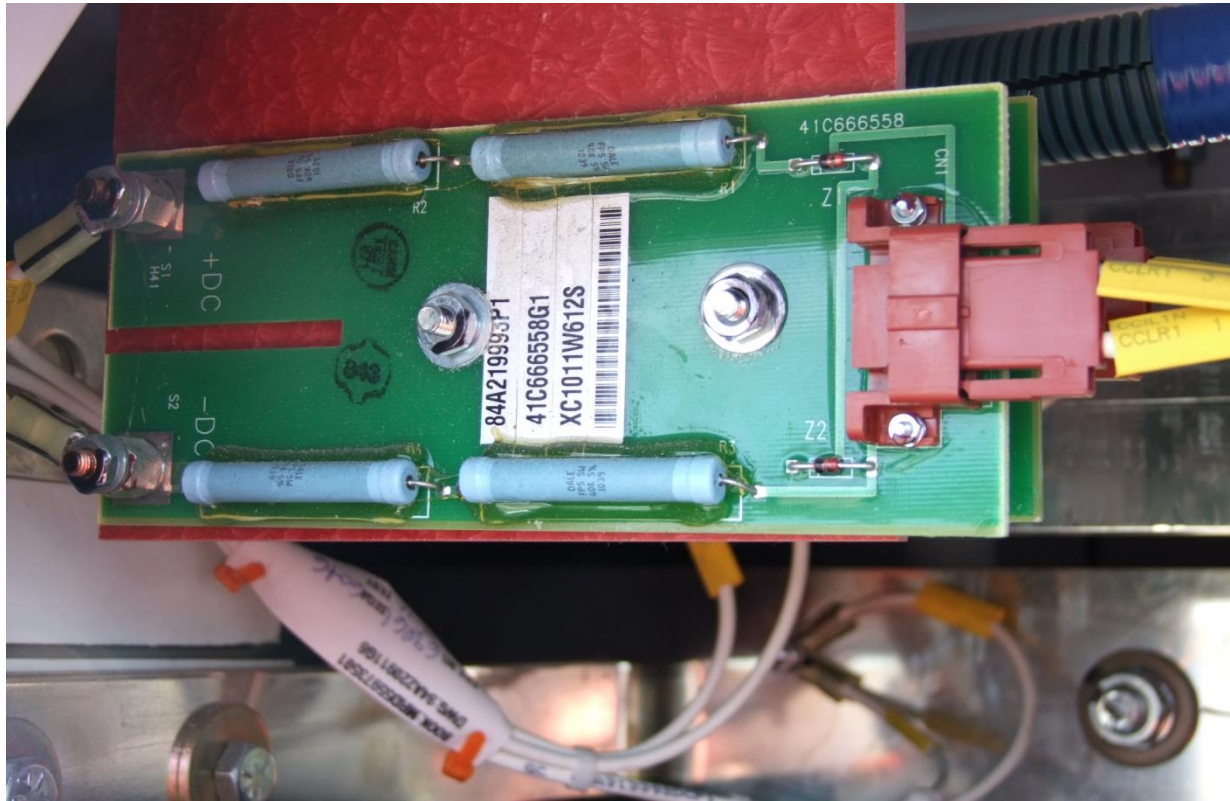

Capacitor Charge Lights

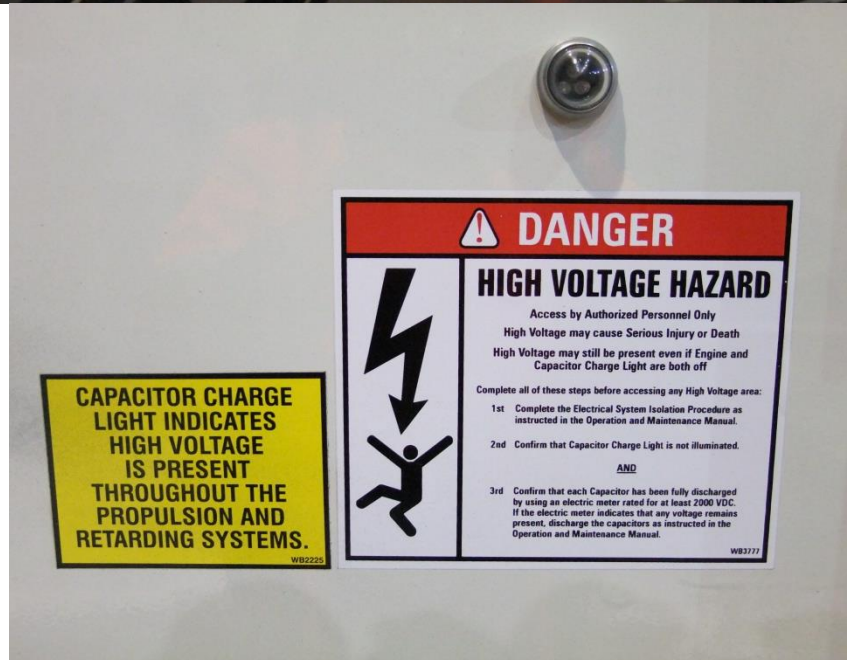

Diagnostic Information Display

17FM558 Standard DID or 17FM693 Enhanced DID

